



**INSTRUCTION MANUAL
FOR USE
AND MAINTENANCE**



CE

MW1901

Index

By	Description
0	Analytical index of the operating and maintenance manual
Index	2
Analytical index of the operating and maintenance manual	2
Scope of the operating and maintenance manual	4
Storage of the instruction manual	5
Updating of the Instruction Manual	5
Glossary and pictograms	6
Manufacturer’s identification data	10
Machine identification and data plates (if they are present)	11
Declarations	11
Guarantee activation form (with repairs by authorised centres)	13
General description of the machine	14
Technical data of the MW1901 T unit	16
Technical data of the MW1901 H unit	17
Description of machine components	18
INSTALLATION	19
Mounting and fixing the equipment	19
Reverse the orientation	22
Electrical connections	24
Electrical protection panel	26
MAINTENANCE OF THE MACHINE	27
Replacement of the filters	27
Filter System Option for 95% Filtration Efficiency.....	28
Filter system option with 99% Hepa Filter Option.....	29
Malfunctions	30
Programmed Maintenance Table	31
OPERATOR NOTES	32



Detail of maintenance operations of the equipment32

***SPARE FILTERS* 33**

Filter Codes33

INTRODUCTION

By	Description
1	Scope of the operating and maintenance manual

This instruction manual is an integral part of the machine and has the purpose of providing all the necessary information for the following purposes:

- Raise the awareness of operators as regards safety matters;
- Safe handling of the machine when packaged and unpackaged;
- Correct installation of the machine;
- Thorough knowledge of the machine's operations and limits;
- Correct use in total safety;
- Correct and safe maintenance;
- Dismantling of the machine in total safety, in compliance with the regulations in force on the health and safety of workers and the environment.



The people in charge of the company's departments in which this machine will be installed must, according to the regulations in force, carefully read the content of this Operating Manual and ensure that operators and maintenance staff operating and working on the machine read the relevant parts.

The time dedicated to this will be fully rewarded by the correct and safe operation of the machine.

This document is based on the assumption that the systems in which the machine is to be installed are in compliance with the health and safety at work regulations in force.

The instructions, drawings and documentation contained in this Manual are of a technical confidential nature and are property of the manufacturer; they may not be reproduced in any way, in part or fully.

If this manual is amended by the manufacturer, the Customer has the responsibility of ensuring that only the updated versions are available in the points of use.

INTRODUCTION

By	Description
2	Storage of the instruction manual

The instruction manual must be kept safely and must be handed over to new owners in case of sale throughout the life cycle of the machine.

To help preserve the manual in good condition it must be handled with care and with clean hands, and it must not be placed on dirty surfaces.

It is forbidden to remove, tear out or arbitrarily modify any parts of the manual.

The manual must be stored in an environment away from humidity and heat, in a position near the machines to which it refers.

Upon the User's request the Manufacturer shall supply other copies of the machine's instruction manual.

INTRODUCTION

By	Description
3	Updating of the Instruction Manual

The manufacturer reserves the right to modify the project and improve the machine without informing customers and without updating the manual already delivered to the User.

If modifications are made to a machine installed at the customer's premises, in agreement with the manufacturer, and which entail the amendment of one or more chapters of the manual, the manufacturer shall send the amended chapters to the holders of the Instruction Manual and its new overall revision.

According to the instructions that will accompany the updated documentation, the User shall replace the old chapters in the copies held with the new ones, as well as the first page and table of contents with the new revision level.

INTRODUCTION

By	Description
4	Glossary and pictograms

This paragraph lists some terms which are not commonly used or with a meaning different from the common one. The meaning of the abbreviations and pictograms used is described below. The abbreviations and pictograms are used to indicate operator qualifications and state of the machine; they provide, in a quick and univocal manner, the information necessary for the correct and safe use of the machine.

GLOSSARY (Annex I point. 1.1.1 Dir. 2006/42/EC)

HAZARD

A potential source of injury or damage to health;

DANGER AREA

Any zone within and/or around machinery in which a person is subject to a risk to his health or safety;

EXPOSED PERSON

Any person wholly or partially in a danger zone;

OPERATOR

The person or persons installing, operating, adjusting, maintaining, cleaning, repairing or moving machinery;

RISK

A combination of the probability and the degree of an injury or damage to health that can arise in a hazardous situation;

GUARD

A part of the machinery used specifically to provide protection by means of a physical barrier;

PROTECTIVE DEVICE

A device (other than a guard) which reduces the risk, either alone or in conjunction with a guard;

INTENDED USE

The use of machinery in accordance with the information provided in the instructions for use;

REASONABLY FORESEEABLE MISUSE

The use of the machinery in a way not intended in the instructions for use, but which may result from readily predictable human behaviour.

OTHER DEFINITIONS

MAN-MACHINERY INTERACTION

Any situation in which the operator interacts with machinery in any of the operating phases during the life cycle of the machinery.

OPERATOR QUALIFICATIONS

Minimum level of skill that an operator must have to carry out the described operation.

NUMBER OF OPERATORS

The suitable number of operators, able to carry out the operation described in an optimal way, as established by a careful manufacturer analysis, whereby a different number of operators might not make it possible to obtain the expected result or might endanger the safety of the personnel involved.

STATE OF THE MACHINE

The state of the machine includes operating modes, for example automatic running mode, jog command, stop, etc., the condition of the safety devices on the machines such as protection devices provided (or not provided), pressed emergency button, type of isolation from energy sources, etc.

RESIDUAL RISK

Risks that persist despite the adoption of the protective measures included in the design of the machine and despite the additional protective devices and measures adopted.

SAFETY DEVICE

Device:

- That carries out a safety function;
- which, when faulty and/or broken, endangers the safety of people.

(e.g. lifting equipment; fixed, mobile, adjustable protective device, etc., electric, electronic, optical, pneumatic, hydraulic device interlocking a protection device, etc.).

PICTOGRAMS

The descriptions that follow this pictogram contain: very important information/instructions, in particular as regards safety.

Failure to respect them may lead to:

- danger for the safety of the operators;
- loss of contractual guarantee;
- waiver of the manufacturer’s liabilities.

PICTOGRAMS CONCERNING OPERATOR QUALIFICATIONS





Symbol	Description
	Unskilled worker: operator without specific skills that can only carry out simple tasks following the instructions of qualified technicians.
	Driver of lifting and handling means: operator qualified to use machines and material handling and lifting equipment (strictly following the manufacturer’s instructions), according to the laws in force in the country of use of the machine.
	Mechanical service You: a qualified technician that can manage the machine in normal conditions, operate in jog mode with the protection devices disabled and work on its mechanical parts to make the necessary adjustments, repairs and maintenance. Usually he is not qualified to work on live electrical systems.
	Electrical service man: a qualified technician that can use the machine in normal conditions, operate in jog mode with the protection devices disabled and work on electrical parts to make the necessary adjustments, repairs and maintenance. He can work on live cabinets and junction boxes.
	Manufacturer’s technician: qualified technician provided by the manufacturer to carry out complex operations in particular situations, or in any case as agreed with the user. According to the situation the technician will have mechanical and/or electrical and/or electronic and/or software skills.

Table 0 - 4.1

PICTOGRAMS CONCERNING THE STATE OF THE MACHINE

Pictograms inside a square/rectangle provide INFORMATION.





Symbol	Description
	Machine off: with hydraulic or electric power supply disconnected.
	Machine on: with hydraulic or electric power supply connected and in safe stop condition with open mobile protective devices (specifying which); JOG disabled; fixed protection devices closed.
	Machine on: with hydraulic or electric power supply connected and in safe stop condition with emergency mushroom button pressed or other control with the same function activated, positioned near the intervention area (specifying the mushroom button or the device to be used).
	Machine moving: in automatic mode, with mobile protection devices closed, the relevant interlocking devices activated, and the fixed protection devices closed.
	Machine moving: in JOG mode, with mobile protection devices closed, the relevant interlocking devices activated, and the fixed protection devices closed.
	Machine moving: in JOG mode, with one or more mobile protection devices, that can be disabled, open (specifying which) with the relevant interlocking devices activated and fixed protection devices closed.
	Machine on: in stand-by and waiting for functional consent to start (e.g. presence of product), mobile protection devices closed with safety device closed, and fixed protection devices closed.

Table 0 - 4.2

SAFETY SIGNS

- The pictograms inside a triangle indicate **DANGER**;
- The pictograms inside a circle mean **PROHIBITION/OBLIGATION**.

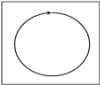

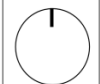
Symbol	Description
	Dangerous electric to voltage
	Danger of crushing of upper limbs
	Danger of entanglement
	Danger of being dragged by machine parts
	General hazard
	Danger of entanglement in transmission belt
	Hot surfaces; danger of burning
	Danger of being dragged by impellers or rotating parts
	No access to unauthorised people
	Do not remove safety devices
	Do not manually clean, oil, grease, repair or adjust moving parts
	Do not carry out any work without disconnecting the power
	Protective gloves must be worn
	Safety footwear must be worn
	Safety helmets must be worn

Table 0 - 4.3

GENERAL INFORMATION

By	Description
1	Supplier identification data

Importer & Distributor of MasterWeld Products;

AES Industrial Supplies Ltd

REGISTERED OFFICE – ADMINISTRATIVE OFFICE

Olympic House, Southmead Park, Collett,
Didcot, Oxfordshire, OX11 7WB

AFTER SALES/SPARE PARTS SERVICE

Phone: 0044 (0) 1235 510717

Fax: 0044 (0) 1235 818610

Email: orders@aes-sales.com

CALL CENTRE

Phone: 0800 975 9710

GENERAL INFORMATION

By	Description
2	Machine identification and data plates (if they are present)

Each machine is fitted with a CE plate with indelible identification data. All communications with the supplier or technical assistance centres must refer to the said data.

MODEL: 0000000000000000

Article code

Article bar code

SERIAL NUMBER: 00-000000-0000

Serial number

Rev.:00

The position of the plate on the machine may vary.

GENERAL INFORMATION

By	Description
3	Declarations

The machine is manufactured in conformity with relevant EC Directives, applicable when the machine is put on the market.

ANNEX IV Directive 2006/42/EC

The machine does not belong to the category of machines mentioned in Annex IV to directive 2006/42/EC

EC DECLARATION OF CONFORMITY

(Annex IIA DIR. 2006/42/CE)

Manufactured in Europe for

AES Industrial Supplies Ltd

Company

Olympic House, Southmead Park, Collett

Address

OX11 7WB

Zip code

Oxfordshire

Province

Didcot

City

United Kingdom

Country

DECLARES THAT THE MACHINE

Wall-Mounted Welding Fume Extraction Unit

Description

MW1901

Model

Serial number

Year of manufacture

MW1901

Commercial name

Suction and purification of welding fumes in contexts with occasional processing and with medium-low concentrations containing gas or micro particles in suspension.

Intended use

IS IN COMPLIANCE WITH THE FOLLOWING DIRECTIVES

Directive 2006/42/EC of the European Parliament and Council of 17 may 2006 on machinery and amending directive 95/16/EC.

Directive 2004/10/8/EC of the European Parliament and Council of 15 December 2004 on the approximation of the laws of the member States relating to electromagnetic compatibility.

Directive 2006/95/EC of the European Parliament and Council of 12 December 2006 on the approximation of the laws of Member States relating to electrical equipment designed for use within certain voltage limits.

Reference to harmonised standards:

IN 349:1993 + A1:2008, IN 614-1:2006 + A1:2009, IN 614-2:2000 + A1:2008, IN 626-1:1994 + A1:2008, IN 626-2:1996 + A1:2008, IN 842:1996 + A1:2008, EN 894-1:1997 + A1:2008, EN 894-2:1997 + A1:2008, EN 894-3:2000 + A1:2008, EN 953:1997 + A1:2009, EN 1005-2:2003 + A1:2008, IN 1037:1995 + A1:2008, IN 1037:1995 + A1:2008, IN 1093-1:2008, IN 1093-4:1996 + A1:2008, IN 13478:2001 + A1:2008, EN ISO 13849-1:2008, EN ISO 13849-2:2008, EN ISO 13850:2008, EN ISO 13857:2008, EN ISO 14121-1:2007, EN ISO 14159:2008

AND DECLARES THAT THE TECHNICAL FILE

Has been compiled on behalf of the manufacturer and is kept at:

AES Industrial Supplies Ltd

GENERAL INFORMATION

By	Description
4	Guarantee activation form (with repairs by authorised centres)

BUYER'S DETAILS:

COMPANY NAME ▼

BUSINESS/PROFESSION/DEPARTMENT ▼

USER DATA (Surname and Name) ▼

PLACE OF INSTALLATION ADDRESS ▼

Zip code ▼ CITY ▼
 _____ _____

Telephone ▼ Fax ▼
 _____ _____

Email ▼

Date of purchase ▼

Model ▼

Serial number ▼ accessories ▼
 _____ _____

Section to be filled in and returned in a sealed envelope to:

Olympic House, Southmead Park, Collett, Didcot, Oxfordshire, OX11 7WB

Please enclose also a copy of the purchase document (delivery note, invoice, receipt) showing the date of purchase.

In accordance with article 10 of Law 675/96 data provided in this form shall be recorded on protected electronic supports and shall be treated using computerised systems; data must be provided in order to enter into and execute the contractual relationship established by the Guarantee. Data may be used by AES Industrial Supplies and by specialised companies operating in the UK and abroad on behalf of AES Industrial Supplies, for customer communications.

Check this box if you do not consent to the use of the data provided for purposes other than the management of the Guarantee

Customer's Signature _____



12 MONTH GUARANTEE ACTIVATION REQUEST FORM

This GUARANTEE gives the right to telephone assistance and to interventions by qualified personnel to restore the equipment following problems caused by manufacturing faults; this guarantee is valid for 12 months from the date of purchase.

The guarantee does not cover any damage to the outer enclosures or faults caused by natural events (lightening, flooding, etc), intent, improper use or use of incompatible consumables.

The Guarantee does not cover consumable parts such as filters, flexible hose, lamps, etc.

Any assistance carried out by unauthorised personnel shall invalidate the guarantee,

To benefit from the Guarantee please fill in the upper section of this card and send it in a sealed envelope, within 10 days from the date of purchase of the equipment, to the following address: Olympic House, Southmead Park, Collett, Didcot, Oxfordshire, OX11 7WB

For telephone support or technical assistance please call: 0800 975 9710

GENERAL INFORMATION ON THE MACHINE

By	Description
1	General description of the machine

The portable unit is the ideal solution for the extraction and filtration of welding fumes from variable position work stations with discontinuous welding operations. The gases and fumes given off during welding are captured to prevent them from spreading throughout the workplace; the air containing the contaminants is thoroughly filtered and recycled back to the workplace. This unit is designed for the suction and treatment of dry fumes produced by work processes such as spot or discontinuous welding wire or electrode welding, hence involving the emission of low concentrations of pollutants containing gas or suspended welding slag.

National and international regulations allow the use of these devices in replacement of conventional air cleaners with an articulated arm in special conditions such as occasional or discontinuous use (e.g. 20 hours out of a 40 hour working week) or in conditions in which the work processes are dynamic to the point at which a fixed capture system is ineffective. In addition, the filtration unit also purifies the air in the surrounding environment, thus not only treating the area contaminated by the work process but simultaneously creating air exchange in the workplace and further decreasing the level of pollutants present. To comply with regulations and to obtain high quality filtration with consequent safety for the operator, it is essential to perform correct maintenance/ periodic replacement of the filters, which, in our units, provide high capacity for accumulation of contaminants and very low costs for the filtration sections.

MACHINE CHARACTERISTICS

The group cabinet is equipped with a high efficiency Vacuum cleaner pressure with respect to the filters in place and positioned directly above the articulated arm.

Its small size and versatility of installation, allows you to use the machine even in special conditions where the space available is very few, possibly even for a machine on wheels.

The filtration section depending on the version is as follows:

FILTRATION LEVEL	MW1901 T	MW1901 H
1	METAL PRE-FILTER	METAL PRE-FILTER
2	CORRUGATED FILTER	CORRUGATED FILTER
3	RIGID POCKET BAG FILTER	HEPA FILTER
4	ACTIVATED CARBON FILTER	ACTIVATED CARBON FILTER

MW1901 supports 3 or 4 m length arms; these can be of the following types:

MasterFlex

The internal supporting structure is realised with reinforced steel billet pipes and 6061 aluminium alloy components after CNC worked for T6 in physical state, then anodised to ensure durability despite continuous exposure to fumes.

The flexible covering pipe is an multilayered PVC to guarantee the protection from eventual sparks and a high temperature resistance (max 40°C).

The extraction hood has a square profile for a maximum efficiency of extraction, complete of manual damper for the airflow calibration, anti-intrusion mesh and bridge handle.



MasterTech

The internal supporting structure is realised with reinforced steel billet pipes and 6061 aluminium alloy components after CNC worked for T6 in physical state, then anodised to ensure durability despite continuous exposure to fumes.

The rigid pipe in aluminium allows a high lightness.

The suction hood has a square profile to provide a maximum efficiency of extraction, complete of a manual damper for an airflow calibration, safety anti-intrusion grate and handle.

The wall mounted version are provided with a steel painted bracket for fixing and connection pipe for fume Expulsion.



GENERAL INFORMATION ON THE MACHINE

By	Description
----	-------------

2 | Technical data of the MW1901 T unit

Unit data		MW1901 400 V-1	MW1901 230 V-1	MW1901 400 V-2	MW1901 230 V-2
Suction arm	No	1	1	2	2
Supply voltage	V	400	230	400	230
Mains frequency	Hz	50	50	50	50
Installed power	Kw	1.5	1.5	1.5	1.5
Absorbed current	A	3,2	6,5	3,2	6,5
Maximum extractor fan flow rate	m ³ /h	2500	2500	2500	2500
Extractor fan negative pressure	Pa	1400	1400	1400	1400
IP Protection class		55	55	55	55
ISO insulation class		F	F	F	F
Machine air flow rate	m ³ /h	1300	1300	1300	1300
Machine negative pressure	Pa	630	630	630	630
Filtration efficiency According to EN 779	%	G2 25%	G2 25%	G2 25%	G2 25%
	%	G4 70%	G4 70%	G4 70%	G4 70%
	%	F8 95%	F8 95%	F8 95%	F8 95%
Carbon filter	Kg	10	10	10	10
Sound pressure level	dB(A)	73	73	73	73

GENERAL INFORMATION ON THE MACHINE

By	Description
3	Technical data of the MW1901 H unit

Unit data		MW1901 400 V-1	MW1901 230 V-1	MW1901 400 V-2	MW1901 230 V-2
Suction arm	No	1	1	2	2
Supply voltage	V	400	230	400	230
Mains frequency	Hz	50	50	50	50
Installed power	Kw	1.5	1.5	1.5	1.5
Absorbed current	A	3.2	6.5	3.2	1.7
Maximum extractor fan flow rate	m ³ /h	2500	2500	2500	2500
Extractor fan negative pressure	Pa	1400	1400	1400	1400
IP Protection class		55	55	55	55
ISO insulation class		F	F	F	F
Machine air flow rate	m ³ /h	1200	1200	1200	1200
Machine negative pressure	Pa	630	630	630	630
Filtration efficiency	%	G2 25%	G2 25%	G2 25%	G2 25%
	Acc. EN 779 (G2-G4)	%	G4 70%	G4 70%	G4 70%
	Acc. In 1822 (H12)	%	H12 99.5%	H12 99.5%	H12 99.5%
Carbon filter	Kg	10	10	10	10
Sound pressure level	dB(A)	73	73	73	73

GENERAL INFORMATION ON THE MACHINE

By	Description
4	Description of machine components

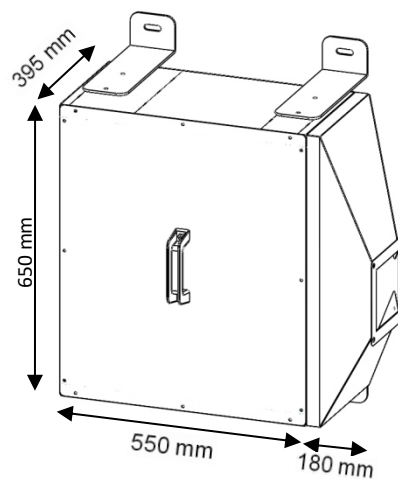
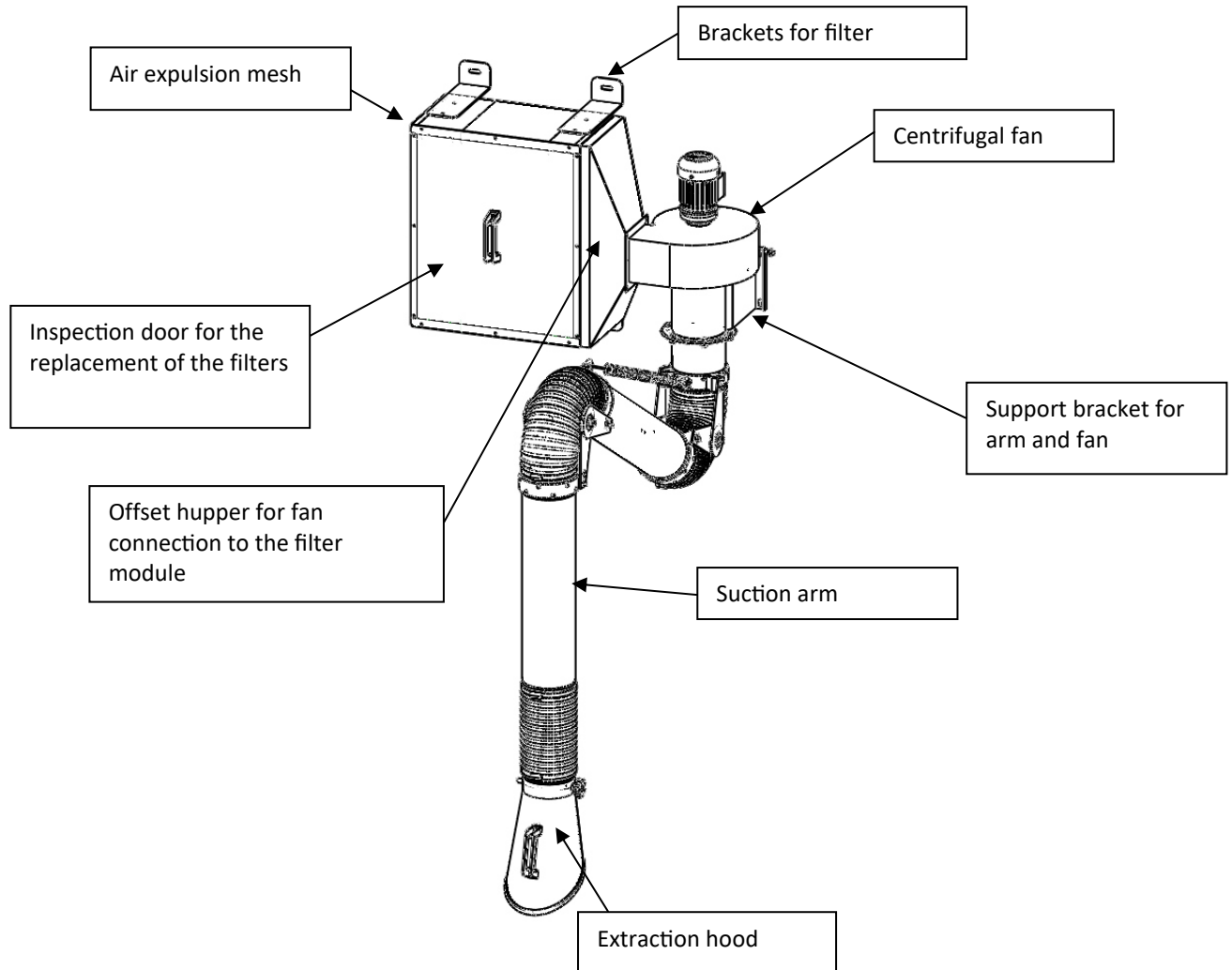

MOVEDTION

By	Description
1	Mounting and fixing the equipment

Fix on the wall shelf black for the support of the fan and of the arm (figure 1).

You must use the screws and wall plugs suitable for the type of construction of the wall; Alt does not provide for the screws and fixing systems. The choice is totally left to the installer who can evaluate the best available technologies.

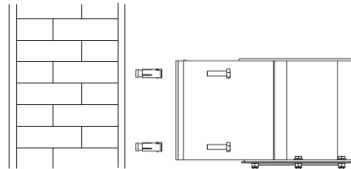

(figure 1)

Lift the suction arm and using the screws provided, attach the turntable rotation to the shelf just clamped to the wall (Figure 2).

During tightening, check that the movement of the arm is fluid and eventually apply the fat spray in sections in contact.

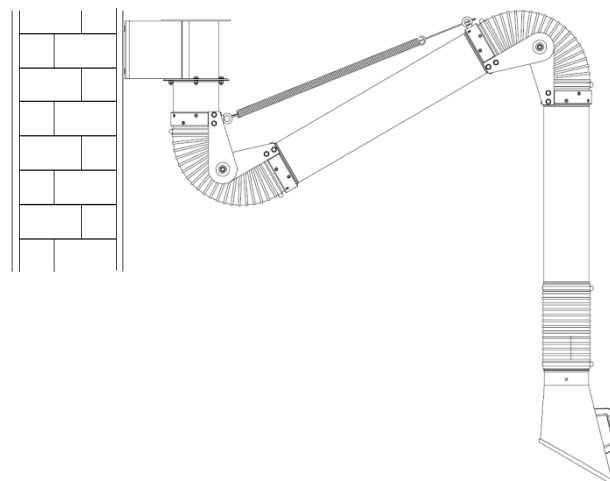

(Figure 2)

Then place the centrifugal fan in the upper flange of the black bracket installed at wall and secure it using the 4 supplied screws (Figure 3). Depending on the space available and the possible impediments to the structure or other devices already installed, you can East the direction of expulsion of air from the fan. In fact it is possible to choose the direction to the right or to the left.

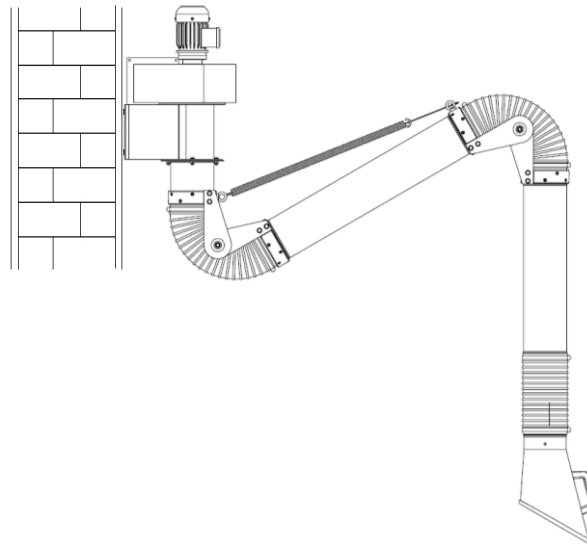

(Figure 3)

Then fix the filter module (Figure 4), the flange of the fan and the flange of the inlet hopper must join together perfectly. You must use the screws and wall plugs suitable for the type of construction of the wall; Alt does not provide for the screws and the fixing systems. The choice is totally left to the installer who can evaluate the best available technologies.

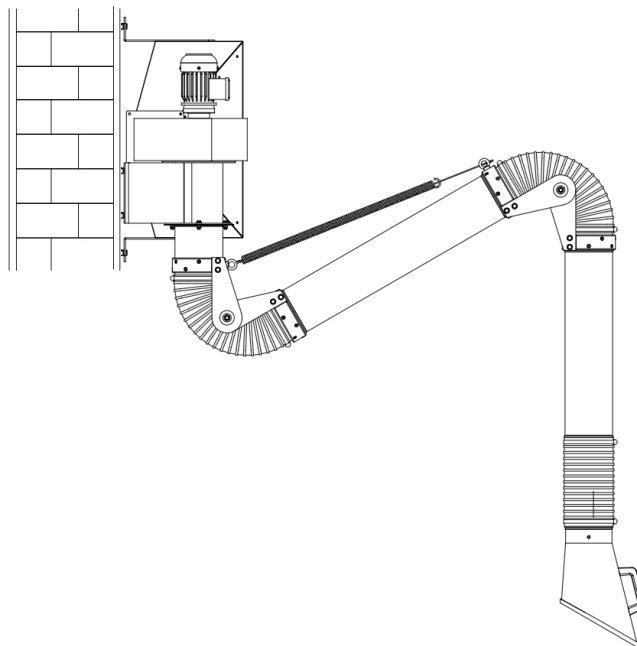

(Figure 4)

At the end of the assembly and fastening the filter module complete with articulated arm and electric turn out to be as shown in figure 5 below.

The version shown is oriented to the right, to change the orientation is sufficient to rotate the various components as specified in section 2: Reverse orientation.

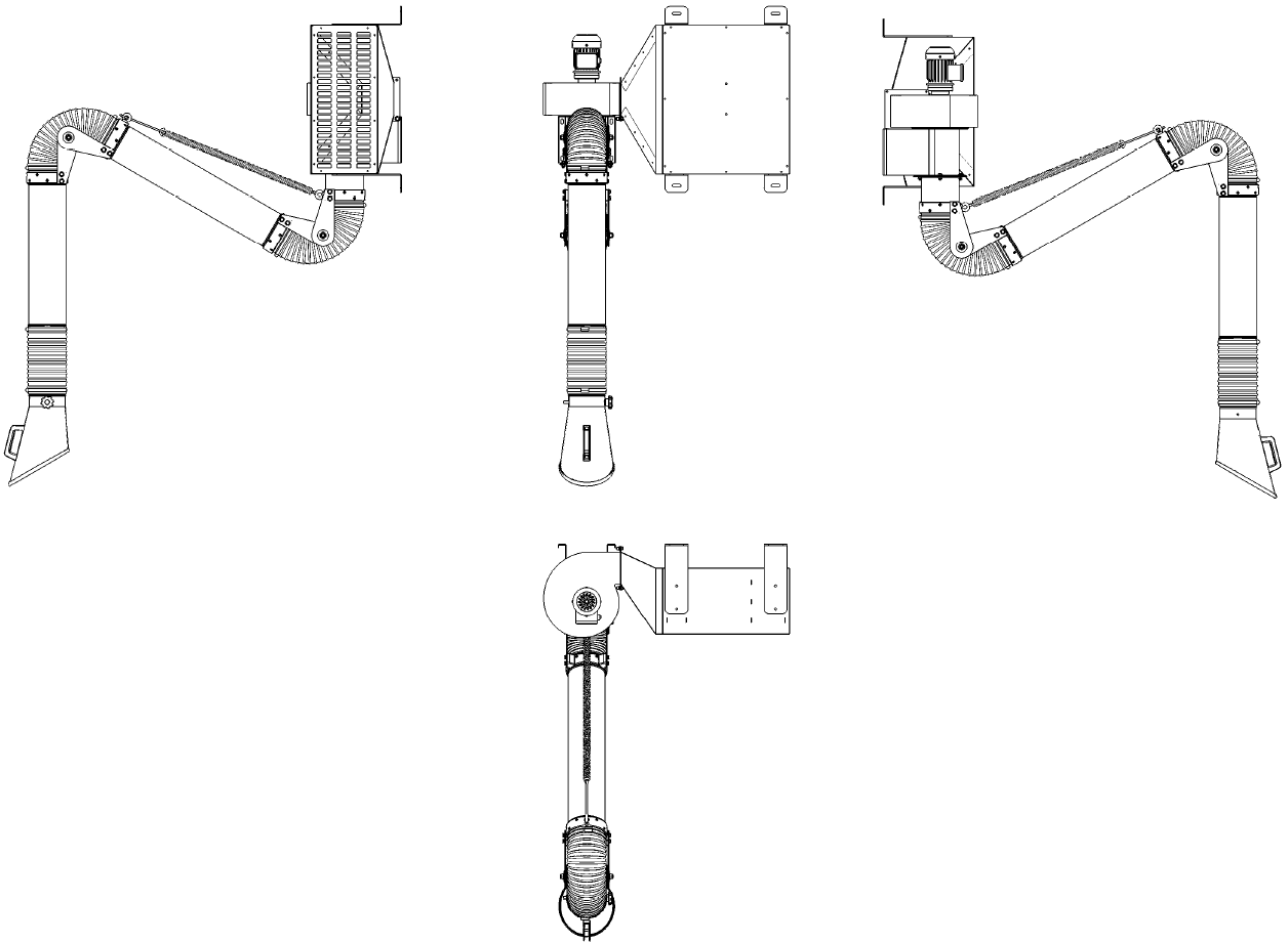

(Figure 5)

MOVEDTION

By	Description
2	Reverse the orientation

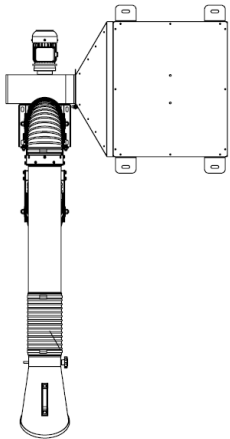

(Figure 1a)

Step 1

Loosen the screws of the flange connection between fan and flange hopper filtration module

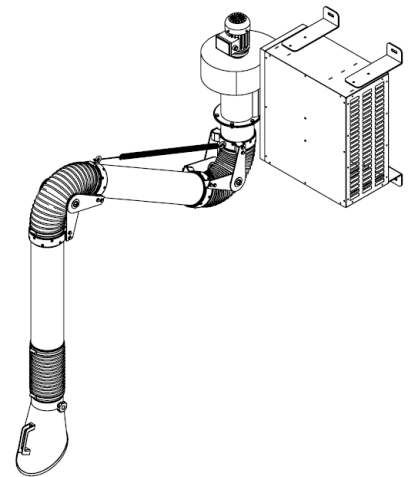

(Figure 1b)

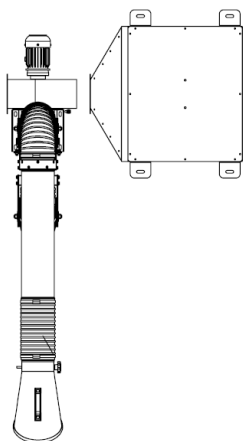

(Figure 2a)

Step 2

Loosen the screws of the connection between fan and support bracket black. Turn the screw in the opposite direction and replace all four screws, being careful to lock them securely.

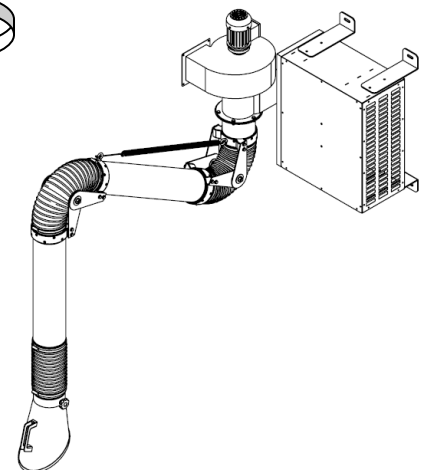

(Figure 2b)

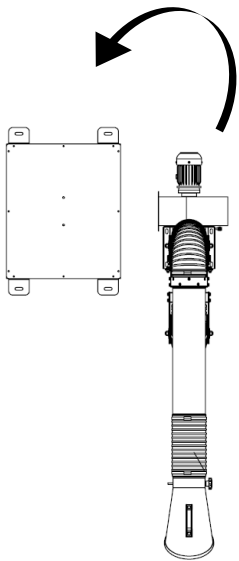

Step 3

Remove the hopper offset and rotate the filter module on the opposite side, making sure to place the mesh of exhaust air to the outside.

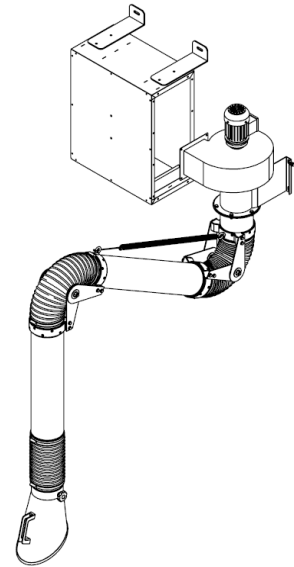

(Figure 3a)

(Figure 3b)

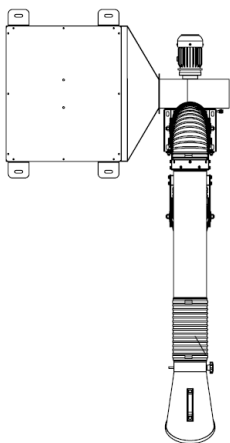

Step 4

Please re-enter the hopper offset rotated 180 ° with respect to the previous position.

Make sure to properly secure the screws inside the hopper for attachment to the filter module, and external for fastening with the flange of the fan.

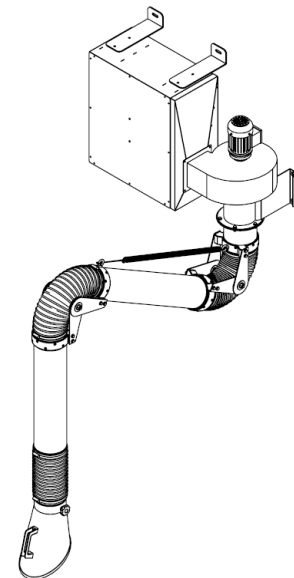

(Figure 4a)

(Figure 4b)

INITIAL START-UP

By	Description
1	Electrical connections

All versions of the portable air cleaner What with a 5 m power supply cable.

In the three-phase electrical power version the cable does not have a plug and therefore it is necessary a plug installation by the user, while the version with single-phase power the cable is already fitted with a wired plug (Photo 3 - 1.1).

SINGLE-PHASE SUPPLY

The terminal box of the electric motor is able to perform the following electrical connections depending on the wished direction of rotation.

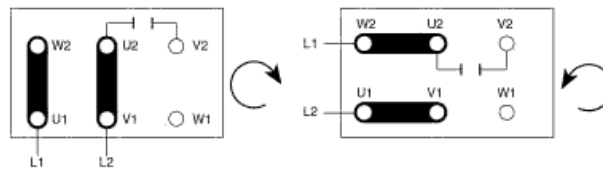

You should ensure that the direction of rotation is in accordance with the arrow indicated in the cochlea of the electric motor, otherwise the fan will run in the opposite direction causing an over-absorption of current which will trigger the electrical protection of the machine.

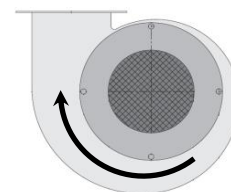
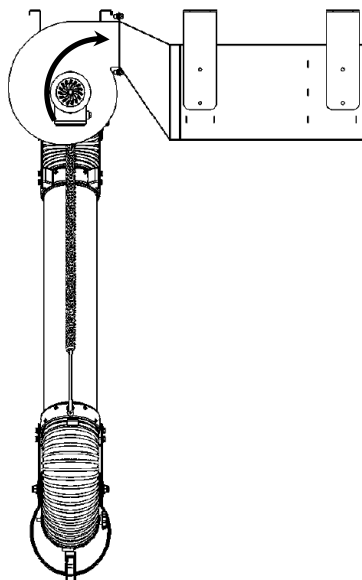

Direction of rotation of the electric motor

THREE PHASE POWER

The terminal box of the electric motor is able to perform the following electrical connections depending on the wished direction of rotation.

D CONNECTION

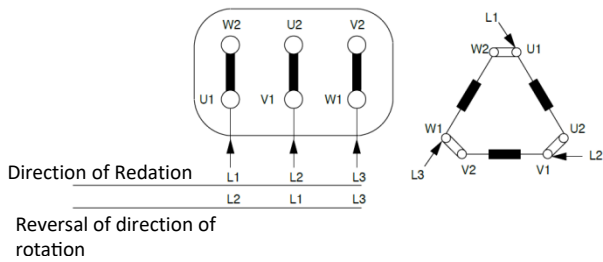

Y CONNECTION

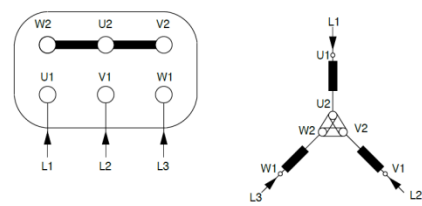

You should ensure that the direction of rotation is in accordance with the arrow indicated in the cochlea of the electric motor, otherwise the fan will run in the opposite direction causing an over-absorption of current which will trigger the electrical protection of the machine.

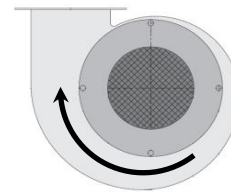
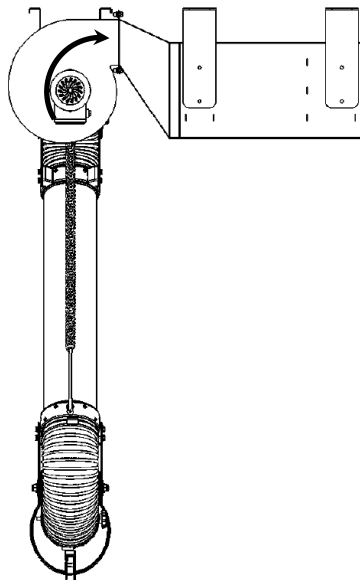

Direction of rotation of the electric motor

INITIAL START-UP

By	Description
2	Electrical protection panel

The wall unit is not equipped with electrical protection / control of the fan assembly. This is a unique responsibility of the customer.

For the correct operation it is necessary to provide an appropriate electrical panel, which is connected exclusively to the electric motor of the MW1901 module, which will act both as a dashboard (on-off) and by protection.

AES recommend using the electrical panels that have as minimum requirements:

- 1- Resorts ON-OFF;
- 2- Overload protection (to be calibrated according to the data of the electric motor);
- 3- Operation alerted by lamp;
- 4- Voltage presence indicated by lamp.

For the best performance and / or maintenance of the product, AES proposes to use a complete electric panel, in addition to the previous points, including:

- 1 - Phase sequence relay (with three-phase power 400/3/50);
- 2 - Safety switch.

MAINTENANCE OF THE MACHINE

By	Description
1	Replacement of the filters

The replacement of the filters, which implies a clogging of the same, may vary in terms of frequency and duration time according to the type of use.

In fact, the variables to consider are many, including:

- welded material (each material produces different welding fumes);
- type of welding (each welding method, MIG, TIG or MMA, etc.. produce different fumes);
- elements in contact (eg oil, grease, paint, etc.. can increase the amount of welding fume).

The clogging of the filters is also evident from the suction capacity of the device, as in the processing stage if the smoke generated is hard or not sucked means that the filters are saturated and then you need to replace or clean the filters.

To replace the filters it is necessary to have a normal Allen wrench (Photo 4 - 1.1), by which action can be taken on the screws of the inspection port filters.

Opening it you have access directly to the filtering section and pulling a filter at a time to the outside can be extracted all the filters.



Photo 4 -

It is important to keep in mind that the filter section may be difficult to remove because of the gaskets around the perimeter of the filters. Such seals (which have been put in pressure) allow the maximum sealing of the whole filter section and therefore give the guarantee that all the aspirated particulate is filtered by the whole section.

The extraction of the filters must be made starting from the pocket filter which has a frame on which you can grip to remove it; below the other filters you can pull in a simplified manner is no longer under pressure.

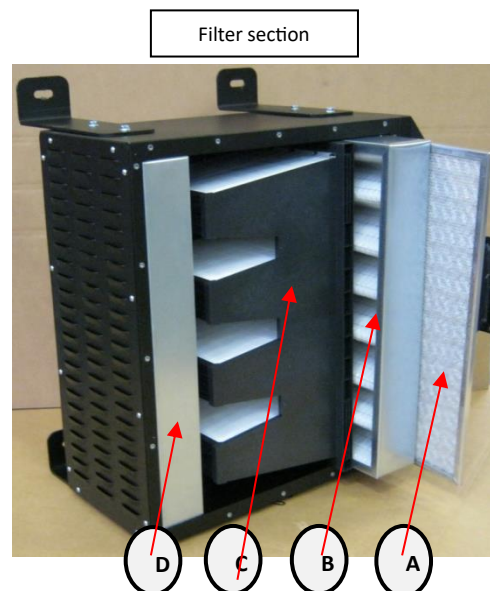

It is recommended to replace all filters provided every 12 months in the device to still maintain maximum performance, suction and filtration.

MAINTENANCE OF THE MACHINE

By	Description
2	Filter System Option for 95% Filtration Efficiency

FIRST STAGE OF FILTRATION

Aluminium Pre-Filter

Filter code: S.1701-APF



Dimensions	mm	287x592
Filtering material	Aluminium fibre	
Re-usability	Yes (cleanable)	
Fire behaviour	Not flammable	



It is suggested to clean this filter at least once a week.

SECOND STAGE OF FILTRATION

F12 Corrugated Filter

Filter Code: S.1701-IM

Disposal

Corrugated and metallic filters are made of inert materials which, if not polluted by toxic-harmful substances deriving from use, can be disposed of as solid urban waste.



Size	mm	287x592
Filtering Material	Polyester fibre	
Reusable	No	
Flammable behaviour	DIN 53438 F1	



We recommend cleaning this filter at least once every two weeks to maintain optimum machine performance.

THIRD STAGE OF FILTRATION

Main Rigid Pocket Filter R-95

Filter Code: S.1701-R95

Disposal

These rigid pocket filters use materials that can be completely incinerated/disposed of without the emission of any toxic gas.



Size	mm	287x592
Filtering Material	Glass Fibre	
Reusable	No	
Flammable behaviour	M1	



We recommend cleaning this filter at least once a month to maintain optimum machine performance.

FOURTH STAGE OF FILTRATION

Wireter type – Active Carbon

Filter Code: S.1701-ACF

Disposal

Active carbon filters can be completely incinerated/disposed of without the emission of any toxic gas.



Size	mm	287x592
Filter Material	Activated Carbons	
Carbon Type	Vegetable Type	
Reusable	No	



We recommend replacing this filter at least once a year to maintain optimum machine performance.

MAINTENANCE OF THE MACHINE

By	Description
3	Filter system option with 99% Hepa Filter Option

FIRST STAGE OF FILTRATION

Aluminium Pre-Filter

Filter code: S.1701-APF



Dimensions	mm	287x592
Filtering material	Aluminium fibre	
Re-usability	Yes (cleanable)	
Fire behaviour	Not flammable	



It is suggested to clean this filter at least once a week.

SECOND STAGE OF FILTRATION

F12 Corrugated Filter

Filter Code: S.1701-IM

Disposal

Corrugated and metallic filters are made of inert materials which, if not polluted by toxic-harmful substances deriving from use, can be disposed of as solid urban waste.



Dimensions	mm	287x592
Filtering Material	Polyester fibre	
Reusable	No	
Flammable Behaviour	DIN 53438 F1	



We recommend cleaning this filter at least once every two weeks to maintain optimum machine performance.

THIRD STAGE OF FILTRATION

Rigid HEPA Filter

Filter Code: S.1701-R99

Disposable

HEPA Filter use materials that can be completely incinerated/disposed of without the emission of any toxic gas.



Dimensions	mm	287x592
Filter Material	H13 Glass Fibre	
Reusable	No	
Flammable Behaviour	M1	



We recommend cleaning this filter at least once a month to maintain the optimum machine performance.

FOURTH STAGE OF FILTRATION

Filter type – Active Carbon

Filter Code: S.1701-ACF

Disposal

Active carbon filters can be completely incinerated/disposed of without the emission of any toxic gas.



Size	mm	287x592
Filter Material	Activated Carbons	
Carbon Type	Vegetable Type	
Reusable	No	



We recommend replacing this filter at least once a year to maintain optimum machine performance.

MAINTENANCE OF THE MACHINE

By	Description
4	Malfunctions

TYPES OF FAULTS	Cause	Intervention
STARTING DIFFICULT	Voltage Of Power Reduced	Verify Data Of targa Of Engine And The Power of network
	Lack Of Power	Verify The Link Of Plug and/or socket Power
IMPOSSIBILITY OF STARTING	Lack Of Power	Verify The Link Of Plug and/or socket Power
	Engine Burned	Replace The vacuum cleaner
	The Micro of Security (It This) It's not Closed Or Is Broken	Make sure That What Door Is Closed Correctly And That The micro Yes Active, Possibly Replace The Particular.
ABSORBED POWER HIGHER THAN THAT INDICATED ON THE IDENTIFICATION AND/OR RATING LABEL OF THE MOTOR	The Engine Tour Below Of His Normal Speed Of Rotation	Verify The Voltage Of Power. Verify Defects In winding Of Engine And if Must Replace.
EC VIBRATIONSCESSIVE	Imbalances Of Party Rotating	Verify equilibration Of Party Rotating
	Anti-vibration mounts Loose The Unfit	Verify The Correct Tightening Of Anti-vibration Mounts And the Their Integrity
LITTLE ASPIRATION	Rotation Incorrect Engine Electric	Reverse i Links Electric On Plug In Case Of Power Three-phase Or On Engine In Case Is Single-phase.
	Filters Clogged	Check What Was Of Filters And the Reporting On Framework Electric; in Case Replace i Filters With a new set.
	Losses of air On Machine	Verify That On Carpentry There Are Drafty of air The Side Openings. If Can Try Of Seal The All With silicone.
	Impeller Unbalanced	Check What Was Of Impeller Checking That Not Have Party Routes Or Dirt On pale. Remove The Group ventilating And Clean Completely The Impeller.

MAINTENANCE OF THE MACHINE

By	Description
5	Table Of Maintenance Scheduled

Periodic

	TYPE OF VERIFICATION OR MAINTENANCE	Method	Cadence	DATE VERIFICATION AND MAINTAINER NAME				
				1	2	3	4	5
1	GENERAL CONTROL OF THE STATE OF THE AIR PURIFIER	Visual	Daily					
2	Cleaning	Manual	See Note A					
3	CHECKING THE CONDITION OF THE SEALS	Visual	150 HOURS					
4	CONTROL OF THE TIGHTENING OF THE BOLTS	Manual	150 HOURS					
5	FILTER CLOGGING CONTROL	VISUAL OR MANUAL	600 HOURS See Note B					
6	CHECKING THE VACUUM CLEANER	Manual	See Note C					
7	BEARINGS CHANGE	Manual	40000 HOURS See Note D					

NOTE THE

The Intervals of Cleaning Are Closely in Correlation To Type Of Fluid Carried To To His Concentration, Over That The environment Of Work To which it is Exposed. Is So Must That The user Final Determine A cadence of Cleaning Such That The Machine Is All the time Perfectly Clean And That On Party Fixed Not Yes Are a Create Accumulations Of Material Stratified For Over 5 mm of Thickness.

NOTE B

The Replacement Of Filters Is Reported From one Affixed Device This Of Series On the equipments Anyway Should Check What Was Of Clogging In order to Can Have All the time The Maximum Suction And the Maximum Efficiency Of Machine And So Would Preferable Give a cadence of Cleaning What Indicated In Paragraph Of Detail Filters Over That Replace At least A Time Per year All The Set of Filters. Also If you don't Used Often i Filters Yes Deteriorate Anyway.

NOTE C

Is Must Monitor The vacuum cleaner With a cadence Determined By the user For Verify The Correct Operation, That There Are Damage The Breaks To Impeller And That The Engine Electric Is in Good Conditions.

NOTE D

This Is The Life Time for The Which one Are States Sized i Bearings, This Not Removes That For causes External, What Can Be Vibration Higher To Standard For Some Periods The Replacement Should Future Also i Periods More Short. Ending The Their Cycle of Life, Also Is Apparently Not Have Problems Yes Recommend Of Make Anyway The Replacement Of Bearings.

OPERATOR NOTES

By	Description
1	Detail of maintenance operations of the equipment

The following table must be completed by a technician specialised and authorised by AES Industrial Supplies Ltd

It is very important to keep these notes up to date so that you can have an emotional history about the problems and maintenance performed; In this way future mis-operations could be arranged in a short time and with the least economic expenditure.

DATA	Name	REFERENCE PERSON	OPERATION PERFORMED
------	------	------------------	---------------------

			<i><u>First start</u></i>

REPLACEMENT FILTERS

Pt	Description
1	Filter Codes

Product Code	Description	Inage
S.1701-R95	Main Rigid Pocket Filter F18 95 287x592x292 F8 95 % 1≥P>0,3 μm for MW1901	
S.1701-R99	Rigid HEPA Filter F18 95 287x592x292 F8 99 % 1≥P>0,3 μm for MW1901	
S.1701-APF	Aluminium Pre-Filter F15 NOW 287x592x12 G2 25% 10 ≥ P μm	
S.1701-IM	F12 Corrugated Filter 287x592x98 EU4-G4 70% 10≥P>3 μm	
S.1701-ACF	Activate Carbon Filter MW1901 287x592x 10 Kg	

Phone: +44 (0) 1235 510717
Fax: +44 (0) 1235 818610
Email: orders@aes-sales.com
Website: www.1stopweldingshop.com

AES Industrial Supplies Ltd

Olympic House
Southmead Park
Collett
Didcot
Oxfordshire
OX11 7WB