



Stealth-XG

**Weld & Grind Helmet
& Digi-Air PAPR System**

Part No. **6044/6044BT**

Version 1.1 – Last updated 06.11.2020

IMPORTANT NOTICE

Please read these instructions carefully before using this unit

Failure to comply with the instructions may void your warranty and adversely affect your health and safety

PAPR PRECAUTIONS

1. INTRODUCTION

Respirator system is intended to be used to provide protection when the user working in the contamination environment. The equipment is able to filter the contaminate air via the filter build in to the blower and then supply fresh air from breathing tube to the welding faceshield, so that the user can continually working in contamination environment. It is a combined face and breathing protection device for increased safety and comfort during welding. Please read these instructions carefully before unpacking. For proper use, see user instructions or contact manufacturers for help.

2. APPROVALS

The system complies with the requirements of PPE Regulation 2016/425 and European Standard EN 12941: 1998+A2:2008 class TH3 P R S L . The respirator system is designed to provide a supply of filtered air via a breathing tube to a welding headpiece. The equipment can be used in environment that requires a class TH3P breathing protection device. It protects against articulate contamination.

All components used in respirator system must be manufacturer approved parts, and must be used in accordance with the instructions in this manual.

Notified Body: Vyzkumny ustav bezpecnosti prace, v. v. i., Jeruzalémská 1283/9, 11 0 00 Praha 1, Czech Republic (Notified body number 1024)



- 1. The approval is not valid if the product is incorrectly used together with non-approved parts or components.**
- 2. Only the particle filter and pre-filter can be used together with this system. Filters from other manufacturers should under no circumstances be used.**

3. WARNING AND LIMITATIONS TO USE

Before each use, inspect the respirator system for damage and verify it operates properly. Before using the respirator system, test air flow to verify it is providing an adequate volume of air.

Always wear the respirator system and do not remove the head top or turn off the air filter unit until outside the contaminated area, otherwise, there is a risk of high concentration of CO₂ and oxygen level in the head top will fall, thus little or no protection is given.

If you are not sure about the concentration of pollution, or about equipment performance, ask the industrial safety engineer.



The manufacturer is not responsible for injury due to the following incorrect use or incorrect choice of equipment.

Warning:

This respirator devices should be used with well trained person and qualified person only.

Before using the devices ensure you have understood that at very high work rates the pressure in the device may become negative at peak inhalation flow.

Before and during using the devices, attention shall be drawn to possible incorrect use and, where appropriate, the possibility of looped hoses and/or cables becoming caught up.

Before or during using the devices if the devices in the power-off state little or no respirator protection is to be expected, and that this is considered to be an abnormal situation.

Please leave the work place and remove the headgear, when the devices in the power-off state a rapid build-up of carbon dioxide and depletion of oxygen within the hood may occur.

The filters shall only be fitted to the turbo unit and not directly to the helmet/hood.

The user should not confuse the markings on a filter relating to any standard other than EN 12941 with the classification of this device when used with this filter.

DO NOT use Stealth-XG with the blower unit switched off.

DO NOT use Stealth-XG in an atmosphere₂ that is immediately hazardous to user hygiene or health and/or has oxygen content of less than 19.5% or contains unknown substances.

DO NOT use Stealth-XG in an explosive atmosphere.

DO NOT use Stealth-XG in confined spaces or areas of poor ventilation

DO NOT use Stealth-XG in high winds.

DO NOT alter or modify in any way.

DO NOT touch any of the moving parts.

DO NOT allow water or other liquids to enter the impeller chamber, the filter or battery compartment.

4. UNPACKING/ASSEMBLY

Check that correct number of components has been supplied, as in figure 1.

Check that the apparatus is complete, undamaged and correctly assembled.

Any damaged or defective parts must be replaced before use.



FIGURE 1





The package must include:

1. The helmet with airduct
2. The respirator protection system (turbo unit + filter + waist belt)
3. Li-ion rechargeable battery
4. The tube with anti-fire cloth and both end fittings
5. The shoulder harness

- 6. The air flow tester
- 7. The lithium-ion battery charger
- 8. The carrying bag

If any of the above components are not included in your kit, please contact the supplier immediately.

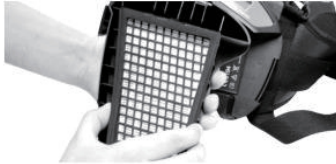
4.1 Filter replacement

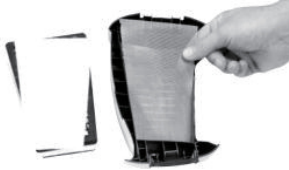
<p>1</p>  <p>Remove the filter cover by pressing in the latch of the filter cover.</p>	<p>2</p>  <p>The filter cover is released.</p>
<p>3</p>  <p>Remove the used filter by lifting it out from the filter cover.</p>	<p>4</p> 
<p>5</p>  <p>Remove the pre-filter.</p>	<p>6</p>  <p>Clean the spark arrester if necessary.</p>



If the filter is wet or heavily loaded with particles or damaged, it should be replaced. Never attempt to clean the filter by any means, it can damage the filter media easily. The pre-filter (if used) should be intact without any tears or cuts. Please replace the prefilter once it's wet or heavily loaded with particulate.

4.2 Installing the battery/Charging

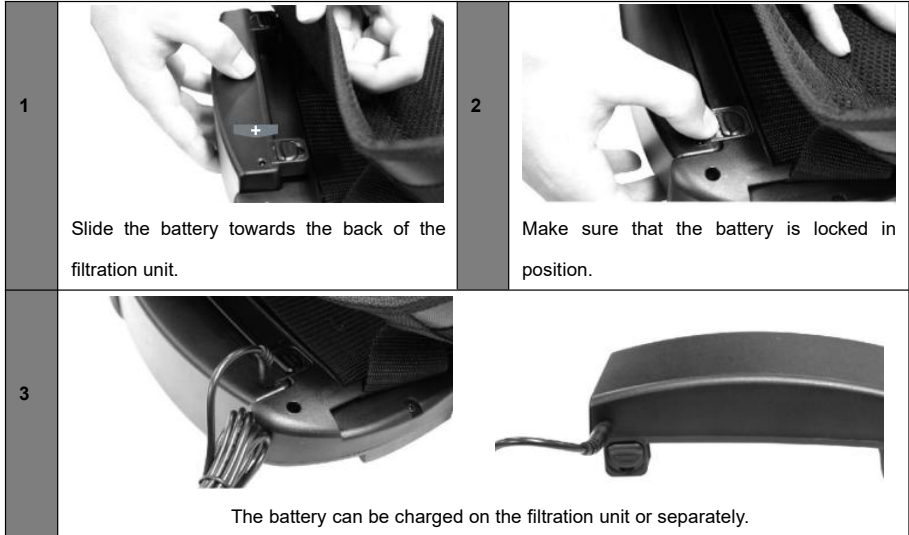

The battery is partially charged when delivered. It must be charged at a 100% (4 bars) before the first use.

⚠ It is recommended to charge the batteries at a 100% before each use.



The charger must not be used for anything else than it was designed for.

Do not charge the battery in a potentially explosive area. The charger must only be used indoors.

The charger regulates the charge automatically, once the battery is fully charged, it will maintain it at a 100% (floating charge).

The charge time is 3 to 4 hours.









The battery will discharge itself after long storage periods. Always charge the battery if the device was stored for more than 15 days. When the battery is new or has been stored for more than 3 months, charge it and discharge it at least twice in a row to reach the nominal/rated charge capacity.

Battery charge :

1. Connect the battery to the charger. The connector is above the battery.
2. Connect the charger to the mains.
3. The state of charge is displayed via a red LED on the mains charger.
4. Once the charge is finished, the floating charge becomes active: the red LED switches off and a green LED switches on.
5. Disconnect the charger from the mains (do not keep the charger plugged to the mains if it's not in use).

4.3 Installing the respirator system on the belt

1	 <p>Remove the belt's release buckle.</p>	2	 <p>Remove the fastening belt from the waist connector's 2 belt loops.</p>
3	 <p>Make the fastening belt pass through the respirator system's 2 belt loops.</p>	4	 <p>Position the Velcro® between the 2 loops.</p>
5	 <p>Flip the filtration system and attach the Velcro on the belt.</p>	6	 <p>Put the fastening belt back through the 2 belt loops.</p>

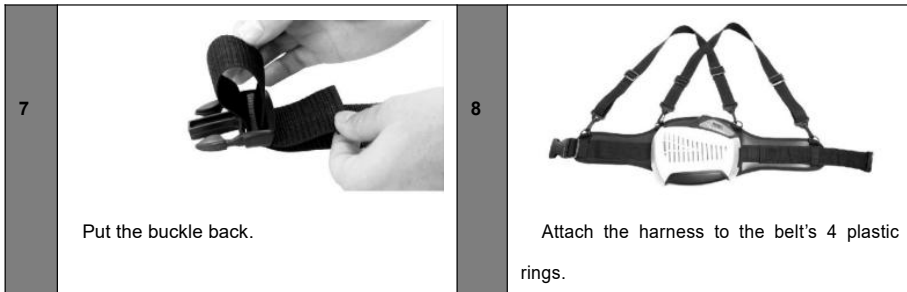

 **Make sure the belt is securely fastened.**

4.4 Connecting the tube

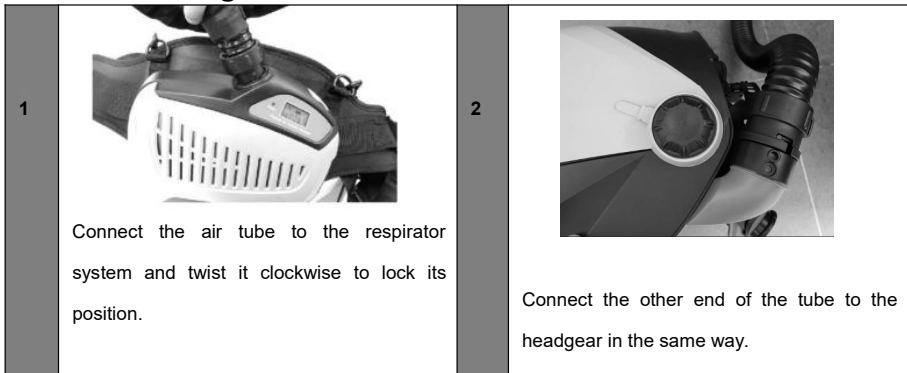





 **1. Check that the respiratory tube is strongly connected. If the tube is broken, replace it.**

 **All components must be installed/ used in accordance with this manual if the equipment is to offer the specified protection. If any component is missing, or if anything is not clear, contact the supplier.**

5. BEFORE USE/ FITTING

5.1 Air flow test



<p>1</p>  <p>Connect the breathing tube to the turbo unit and twist it clockwise to lock it.</p>	<p>2</p>  <p>Insert the flowmeter at the tip of the tube.</p>
<p>3</p>  <p>Press the ON button and maintain the tube in a vertical position at eyes' height.</p>	<p>4</p>  <p>The air flow is sufficient if the marble reaches the minimum flow level O.</p>



1. The airflow must be tested before using.



**2. If the marble can't reach the minimum flow level, don't use the system.
Change the filter or the battery and retest the air flow.**

5.2 Air flow alarm test

<p>1</p>	 <p>Remove the tube from the helmet and press the ON button.</p>	<p>2</p>  <p>Cover the air output with your hand and wait approximately 15 seconds.</p>
----------	---	--

 **If the alarm does not work, please repair or change respirator system.**

5.3 Fitting

<p>1</p>  <p>Adjust</p> <p>Adjust the tightness of the face seal and put on the head top.</p>	<p>2</p>  <p>Adjust the headgear to suitable tightness (turn left to loosen, turn right to tighten)</p>
---	--

 **Make sure the face seal is positioned properly, otherwise, you can't get sufficient sealing needed to offer the correct protection factor.**

6. LCD and Operation

6.1 LCD display screen

There is a LCD display screen on Stealth-XG unit to show the Stealth-XG working condition (FIGURE 3).

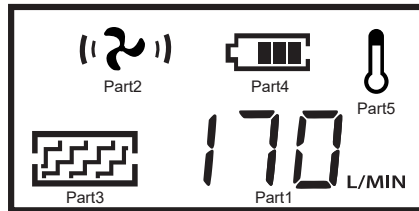

FIGURE 3

- Part 1 shows the data of current air flow.
- Part 2 shows the level of the airflow.
- Part 3 shows the filter condition.
- Part 4 shows the battery.
- Part 5 shows the temperature of the battery.

Any of them will flash if there are Stealth-XG disfunctions.

6.2 Operation

1x ON



Switch the device on by pressing the ON button once.



2x ON



Press the ON button once again, the air flow is at level 1 (~170L/min).



3x ON



Press the ON button once again, the air flow is at level 2 (~200L/min).



4x ON



Press the ON button once again, the air flow is at level 3 (~230L/min)

Press the ON button once again, the air flow reverts to level 1 (~170L/min).



- 1. The respirator system will turn off the turbo unit if long press the OFF button more than 3 seconds.**
- 2. The respirator system will cut off the entire circuit and switch to sleep mode if the turbo unit has turned off for more than 30 minutes. Pressing the ON button can activate the system.**
- 3. The respirator system must be operated in the temperature range of -5°C to +55°C and relative humidity less than 90%RH.**

7. MAINTANCE & STORAGE

Inspect the equipment daily and always check it if any sign of malfunction occurs.

7.1 Maintenance

The respirator system unit must be checked regularly and must be changed if it is damaged and cause leakage.

The filter must be changed if it is broken, or it is blocked and does not give enough airflow.

The breathing tube must be changed if it is broken or has crevasse.

The battery must be charged when the low battery alarm rings.

Use a soft cloth to wipe the external surfaces. Don't use water!

Disinfect the equipment with disinfectant not having any adverse effect on the PPE or the user. Dettol disinfectant is recommended. Dilute the disinfectant and water in a ratio of 1:99. Wipe the surface of the equipment with a clean lint-free tissue or cloth that takes the solvent. Then wipe the surface of the equipment with another clean lint-free tissue or cloth that takes water.

The filter should be replaced together with the pre-filter.

7.2 Storage







The respirator system must be stored in a dry, clean area, in the temperature range of -10°C to +55°C and relative humidity less than 90%RH.

If the equipment is stored at temperature below 0°C, the battery must be allowed to warm up to achieve full battery capacity. The equipment must be protected from dust, particles and other contamination.

If the equipment is not used for a long time, the battery should be fully charged, removed from the respirator system unit and stored separately.

Transport the equipment with original packaging box and away from direct sunlight.

8. TROUBLE SHOOTING

Problem	Probable cause	Action
Fault code «E01» +  blinks	1.Motor is stuck 2.Motor is damaged 3.Blower structure failure caused by outer force 4.Circuit failure	Check and remove physical failure and restart the system. Return to dealer if LCD still shows E01
Fault code «E02» +  blinks	1.Motor is damaged 2.Motor impeller rubs blower shell 3.Circuit has excessive current.	Check and remove physical failure and restart the system. Return to dealer if LCD still shows E02
 blinks +  blinks + alarm sounds	Low battery	Charge the battery
 blinks +  blinks + alarm sounds	Filter blocked Tube blocked	Remove obstruction, change the filter Clean tube
 blinks +alarm sounds	Battery high temperature	Stop working and rest
No air flow, no alarm	1. No power 2.Battery contact damaged	Charge the battery Check battery contact
Battery run time is too short	1.Battery is not fully charged 2. Filter is blocked 3. Battery is damaged	Charge the battery Remove obstruction, change filter Change battery
Air supply to hood smells unusual	1. Filter broken 2. Tube broken 3. ADF helmet broken	Leave current area immediately. 1. Change filter 2. Change tube 3. Change ADF helmet
Supply insufficient air to hood	1. Breathing tube broken off 2. Breathing tube broken 3. Filter is blocked	1. Check tube connection to hood and respirator system unit 2. Change breathing tube
		3.Remove obstruction, change filter

9. SPECIFICATION

Size (Blower Assembly)	9-2/5 x 6-1/2 x 2-3/4 in. (240 x 165 x 70 mm)	
Weight	2.4KG	
Particle Filter	1*TH3 P R SL	
Air Flow	Manufacturer minimum design flow rate: 165L/min Nominal airflow : Level 1: 170L/min Level 2: 200L/min Level 3: 230L/min	
Noise Level	Max 75dB	
Operate Temperature	23°F to 131°F (-5°C~55°C)	
Storage temperature	14°F to 131°F (-10°C~55°C)	
Battery Type	Standard Battery Rechargeable Li-ION 4400mAh Optional: Heavy Duty Battery Rechargeable Li-ION 6800mAh	
Expected Battery Operation Time	Standard battery Level 1>10h Level 2>8h Level 3>6h	Heavy Duty battery (optional) Level 1>15h Level 2>12h Level 3>10h
Battery Charging Time	3.5 Hours	5 hours
Battery Life	500 Charges Run Time Dependent On Air Flow Rate and Filter Load.	
LCD Display	Air flow level and data Battery capacity Filter status	
Belt Size	35-2/5 x 51-2/5 in. (900mm to 1300mm)	

10. MARKING EXPLANATION

Powered filtering device:

- EN 12941:1998 respirator protective devices- powered filtering devices incorporating a helmet or hood- Requirements, testing, marking.
- TH3 P R (SL) classification of the unit. “TH3” defines the level of protection, “P R” indicates the filter type (“P”= Particle filter, “R”= Reusable type of particle filters) and “SL” reflects the filter has been tested against particles of liquid and solid matter.

Warning indication

This Stealth-XG PAPR has sound and vibration alarm function.

Each grid stands for a period of 100ms. Gray is the beep sound and blank grid is a quiet period. If several continued grids are in gray then there's a continuous beep sound.

For example, when the current is overloaded, the system sounds like beep~beep~beep~~~~.

100ms per grid											
	0	1	2	3	4	5	6	7	8	9	10
Install the battery	█										
Turn on the system	█										
Change the air flow speed	█										
Turn off the system	█	█	█	█	█	█	█	█	█	█	█
Current overload	█		█	█	█	█	█	█	█	█	█
Air outlet jam	█		█	█	█	█	█	█	█	█	█
Over heat	█		█	█	█	█	█	█	█	█	█
Low battery	█		█								
Filter jam	█		█		█						

Symbols:



=Read instructions before use

CE 2797 = CE mark followed by number of notified body who carried out module D surveillance.

Warranty:

The Stealth-XG Blower unit is guaranteed for a period of 12 months from date of purchase against mechanical or electrical defects.

The Stealth-XG battery is guaranteed for a period of 6 months from the date of purchase. The company undertakes to exchange or repair without charge, any part found to be defective within this period alternatively and at its discretion. The Company may replace. This guarantee is subject to:

The Stealth-XG unit has been used solely for the purpose for which it is intended.

The Stealth-XG unit has not been subject to misuse, accident, modification or repair.

In the event of a claim, contact the retailer from which the Stealth-XG unit was purchased. The guarantee does not cover normal wear and tear.

AUTO-DARKENING HELMET

INTRODUCTION

The auto-darkening helmet with improved High Definition Filter Optics, delivers a new generation of face and eye protection. Advanced integrated technology, such as LCD, optoelectronics detection, solar power, and microelectronics are coordinated to produce one of the safest, fastest and most reliable auto-darkening helmets available. The auto-darkening helmet can not only efficiently protect operator's eyes and face from sparks, spatter, and harmful radiation under normal welding conditions, but also make both hands free and strike arc accurately resulting in increased efficiency and improved quality welds. It may be widely used for various welding, cutting, spraying and arc gouging, etc.

WARNINGS

- This auto-darkening helmet is not suitable for "overhead" welding, laser welding or oxyacetylene welding applications.
- This helmet will not protect against explosive devices or corrosive liquids. Machine guards or eye splash protection must be used when these hazards are presented.
- Impact resistant, primary eye protection, spectacles or goggles that meet current ANSI specifications must be worn at all times when using this welding helmet.
- Avoid work positions that could expose unprotected areas of the body to spark, spatter, direct and/or reflected radiation. Use adequate protection if exposure cannot be avoided.
- Do not make any modifications to either the ADF cartridge or helmet, other than those specified in this manual.
- Do not use any replacement parts other than those specified in this manual. Unauthorized modifications and replacement parts will void the warranty and expose the user to the risk of personal injury.
- Do not immerse this helmet in water because this model is not waterproof.
- Do not use any solvents on any ADF or helmet components.
- The recommended operating temperature range for this ADF cartridge is -10°C~65°C (14°F~149°F). Do not use this device beyond these temperature limits.

Failure to follow these warnings and/or failure to follow all of the operating instructions could result in severe personal injury.

SPECIFICATIONS (REMOTE)

Specification of ADF	
1.CE Classification	1/1/1/1
2.True Color	Yes
3. LCD Viewing Area	100 x 60 mm (3.94" x 3.28")
4. Light State Shade	DIN 4
5. Dark Variable Shades	DIN 5-9 / 9-13
6. Switching Tme (light to dark)	0.08ms
7. Delay Tme (dark to light)	Adjustable (Level 1-5 for 0.1-0.9s)

8. Sensitivity	Adjustable (Level 1-5 for low-high)
9. Arc Sensors	4
10.Grinding Function	Yes
11. Cutting Function	Yes,Shade 5~8 adjustable
12. Power Supply	Solar cell and Li-ion rechargeable battery
13.ADF Battery Operating Time	>300h
14.Charging Time	2.5h
15. Battery Life	≥500
16. Operating Temperature	-10°C~65°C (14°F~149°F)
17. Inside PC Lens	104.5 x 64 x 1 mm
18. Outside PC Lens	118 x 97 x 1 mm
19. Inner Visor	Clear Visor ,DIN 1
20. Standards	CE EN379, ANSI Z87.1, CSA Z94.3, AS/NZS
21. Warranty	2 years
Specification of Remote	
1.Display	OLED
2.Power Supply	Li-ion rechargeable battery
3.Remote Battery Operating Time	>300h
4.Charging Time	2.5h
5. Battery Life	≥500

OPERATION INSTRUCTION (REMOTE)

BEFORE USE

- Check for light tightness and check the inside & outside protection lens are clean and that no dirt is covering the sensors on the front of the **auto-darkening-filter (ADF)** cartridge.
- Make sure the protection films on both inside & outside protection lens are removed.
- Inspect all operating parts for signs of wear or damage. Any scratched, cracked, or pitted parts should be replaced immediately.

This ADF is fully controlled by a Remote control and connected with Bluetooth. All the adjustment of the ADF is operated on Remote Control. ADF will change to the Function mode you set by the Remote Control.

LED FLASH EXPLANATION ON ADF



There are 3 LED on the ADF showing the working status of the ADF.

1. RUNNING(Green):
 - a. LED will flash once every 2 Sec while pairing with Remote Control
 - b. After succeed paired, LED will flash when ADF receives control signal from Remote Control
2. GRINDING/CUTTING(Orange):
 - a. LED will flash when ADF work in Grinding/Cutting mode
3. LOWPOWER/CHARGING(Red/Green):
 - a. LED will become red when ADF out of power
 - b. LED will be green and will flash while charging
 - c. LED will be green and normally on when charging finished

SCREEN ICON EXPLANATION ON REMOTE CONTROL

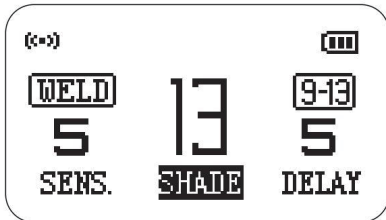

Picture 1

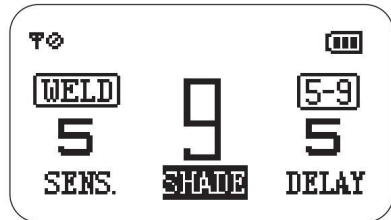

Picture 2

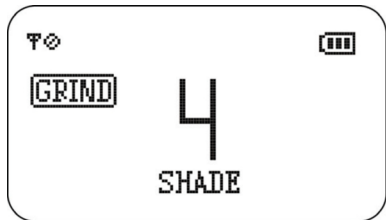

Picture 3

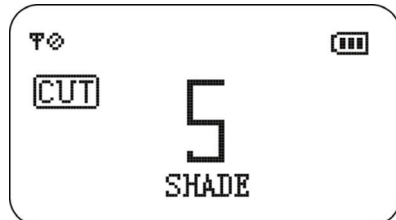

Picture 4

1	2	3	4	5
Battery Status	Connection Signal Indication	Welding Indication	Shade Range 5-9	Shade Range 9-13
6	7	8	9	10
Sensitivity Indication: 1 (low) to 5 (high)	Delay Indication: 1 (short 0.1s) to 5 (long 0.9s)	Shade Reading	Cutting Mode Indication	Grinding Mode Indication

MODE SETTING

- ADF has 4 function modes: Welding mode (Shade range 5-9), Welding mode (Shade range 9-13), grinding mode, Cutting mode. At welding mode 3 functions can be adjusted: Sensitivity, Shade and Delay.
- Long press the button(8) on the Remote Control for 2 Sec and release, the ADF mode will be changed circularly during these 4 modes. LCD display will show the picture from 1 to 4 circulation.
- At welding mode, short-press the button on the Remote Control less than 1 sec and release, the function will be changed circularly during Shade ,Sensitivity and Delay time.

VARIABLE SHADE CONTROL

- If the **Shade** is in the range of **5-9 or range of 9-13**, clockwise rotate the button on the Remote Control, Shade number will be increased; Or Anticlockwise rotate the button on the Remote Control, Shade number will be reduced.

Note:

- Choose an optimum **Shade** number for the required welding process or application (see Table 1).
- If this ADF does not darken when striking arc, stop welding immediately and contact our representative.

SENSITIVITY CONTROL

The responsiveness to different light levels in various welding processes can be adjusted in the range 1-5(from low to high). Sensitivity can only be adjusted at Welding Mode.

- Short press the button (8) on the Remote control and select SENS and Clockwise rotate the button on the Remote Control, Sensitivity will be increased; Or Anticlockwise rotate the button on the Remote Control, Sensitivity will be reduced. After the Icon 6 mentioned is displayed on the screen, number will be changed during 1 to 5.
 - Turn to **level 1 (low)**: The sensitivity changes to be lower.
 - Suitable for high amperage welding and welding in bright light conditions (lamp light or sun light).
 - Turn to **level 5 (high)**: The sensitivity changes to be higher.
 - Suitable for low amperage welding and using in poor light conditions.
 - Suitable for using with steady arc process such as TIG welding.
 - Under normally use, a higher sensitivity setting is recommended.

DELAY CONTROL

The length of time delay for the ADF returns to light state after welding can be adjusted in the range 1-5 (for 0.1~0.9s). The time delay is for protection of welder's eyes from strong residual rays after welding.

- Short press the button (8) on the Remote control and select DELAY and Clockwise rotate the button on the Remote Control, Delay time will be increased; Or Anticlockwise rotate the button on the Remote Control, Delay time will be reduced. After the Icon 7 mentioned is displayed on the screen, number will be changed during 1 to 5.
 - Turn to **level 1 (0.1s)**: The time the ADF lighten after welding to be shorter. The

shortest time is about 0.1s depending upon welding point temperature and shade set. This setting is ideal for track welding or production welding with short welds.

Turn to **level 5 (0.9s)**: The time the ADF lightens after welding to be longer. The longest time is about 0.9s depending upon welding point temperature and shade set. This setting is ideal for welding at high amperage where there is an after-glow from the weld.

GRINDING SELECTION

- Select grinding mode by pressing the button on the Remote Control, Picture 3 mentioned will show on the Remote Control and the orange light on ADF will flash.

Note: Do not weld in the grinding mode, the ADF will not darken.

CUTTING SELECTION

- Select Cutting mode by long pressing the button on the Remote Control for 2 sec and release, Picture 4 will show on the Remote Control and the orange light on ADF will flash.
- Clockwise rotate the button on the Remote Control, Shade number will be increased; Or Anticlockwise rotate the button on the Remote Control, Shade number will be reduced. The Shade range at cutting mode is 5-8.

Note: Do not weld in the cutting mode.

BATTERY INDICATOR

- Icon 1 mentioned indicates the Remote Control battery status. Charge the battery when it is low, otherwise, the Remote Control will out of work.
- Charge the battery of ADF when the light on ADF become red, . Otherwise, switching time will become slower and shade accuracy will be compromised.

POWER SUPPLY AND CHARGE BATTERY

- The power of the auto-darkening helmet is provided by solar cells and rechargeable lithium battery.
- Charge battery with Micro-USB cable when battery power is low. (Pic 5 & Pic 6)



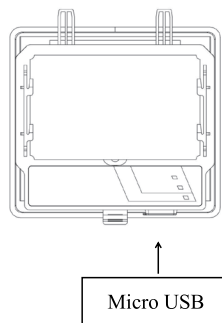

Picture5



Picture 6

REMOTE CONTROL PAIR WITH ADF

- ADF and Remote Control is paired one to one when assemble on the helmet and do not need to be paired again. Icon 2 mentioned will show  .One Remote Control can only control one ADF which has been paired.
- A new Remote Control can be paired with a new ADF. Put new ADF and new Remote Control together. Long press the pair button on the ADF(Picture 7) more than 3 Sec by a fine needle and release .Then long press the pair button on the Remote Control (Picture 8) more than 3 sec and release by a fine needle .Running LED on ADF will flash once every 2 sec and will stop flash when succeed paired .The Icon 2 mentioned will show  ;if Icon 2 shows  , it means fail paired ,and needs to be paired again

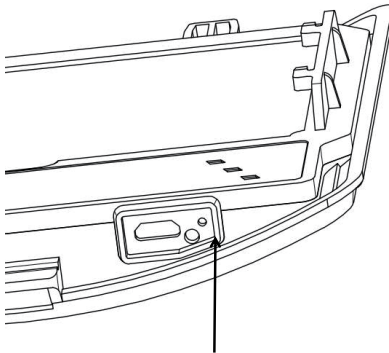

Pair Button

Picture 7

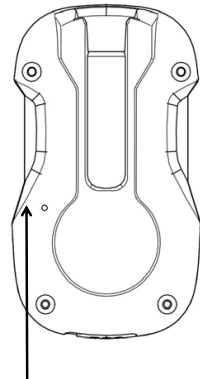

Pair Button

Picture 8

SPECIFICATIONS

Specification of ADF	
1. CE Classification	1/1/1/1
2. True Color	Yes
3. LCD Viewing area	100 x 60 mm (3.94 " x 3.28 ")
4. Light State Shade	DIN4
5. Dark Variable Shades	DIN5-9/9-13
6. Switching time (light to dark)	0.08ms
7. Delay	Adjustable (0.1-0.9s)
8. Sensitivity	Adjustable (low-high)
11. Power Supply	Solar and Li-ion battery CR2032*2
12. Operating Temperature	-10 °C~65 °C (14 °F~149 °F)
13. Inside PC lens	105.8 x 65.8 x 1 mm
14. Outside PC lens	110 x 90 x 1 mm
15. Standards	CE EN379, ANSI Z87.1, CSA Z94.3, AS/NZS
16. Warranty	2 years

OPERATION INSTRUCTION

BEFORE USE

-Check for light tightness and check the inside&outside protection lens are clean and that no dirt is covering the sensors on the front of the **auto-darkening-filter (ADF)** cartridge.

-Make sure the protection films on both inside & outside protection lens are removed.

-Inspect all operating parts for signs of wear or damage. Any scratched, cracked, or pitted parts should be replaced immediately.

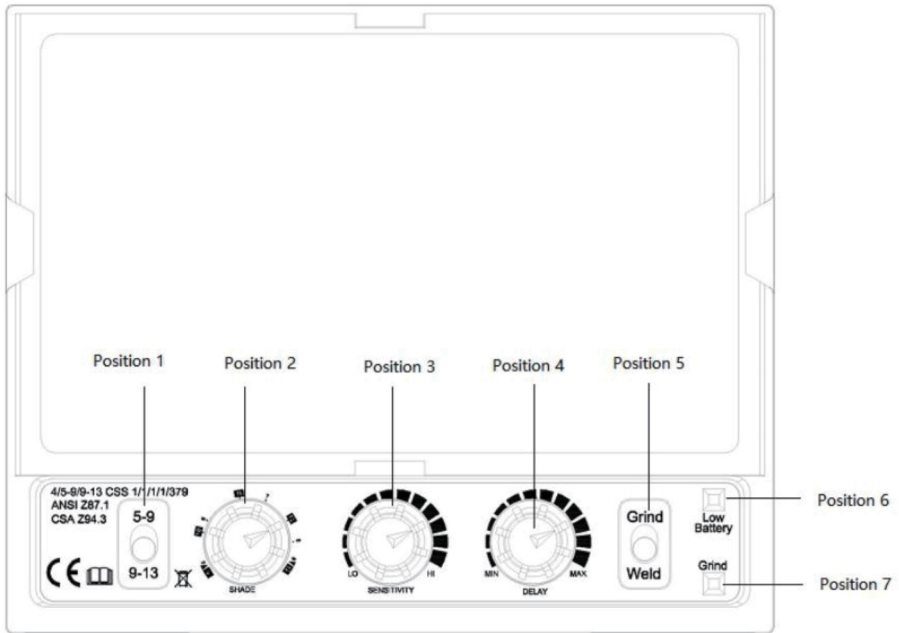

VARIABLE SHADE CONTROL

- Shade range of ADF is 5-9/9-13. Can be switched by a moving the knob on ADF (Position1) and can be adjusted by rotate the shade button (Position 2) on ADF.
- If the **Shade** is in the range of **5~9**, clock wise rotate the button on ADF, Shade number will be increased ; Or Anticlock wise rotate the button on the ADF, Shade number will be reduced.
- If the **Shade** is in the range of **9~13**, clock wise rotate the button on ADF, Shade number will be increased ; Or Anticlock wise rotate the button on the ADF, Shade number will be reduced.

Note :

- Choose an optimum **Shade** number for the required welding process or application (see Table1).
- If this ADF does not darken when striking arc, stop welding immediately and contact our representative.

SENSITIVITY CONTROL

The responsive ness to different light levels in various welding processes can be adjusted between low and high by rotate the SENSIVITY button on ADF(Position 3).

- Clockwise rotate the button on the ADF, Sensitivity will be increased; Or Anticlockwise rotate the button on the ADF, Sensitivity will be reduced.
 - Turn to **low**: The photo sensitivity changes to be lower.
 - Suitable for high amperage welding and welding in bright light conditions (lamp light or sun light).
 - Turn to **high**: The photo sensitivity changes to be higher.
 - Suitable for low amperage welding and using in poor light conditions.
 - Suitable for using with steady arc process such as TIG welding.
 - Under normally use, a higher sensitivity setting is recommended.

DELAY CONTROL

The length of time delay for the ADF returns to light state after welding can be adjusted in the range 0.1~0.9s. The time delay is for protection of welder's eyes from strong residual rays after welding. Delay time can be adjusted by rotate the DELAY button on ADF(Position 4).

- Clockwise rotate the button on the ADF, Delay time will be increased; Or anticlockwise rotate the button on the ADF, Delay time will be reduced.
 - Turn to **min(0.1s)**: The time the ADF lighten after welding to be shorter. The shortest time is about 0.1s depending upon welding point temperature and shade set. This setting is ideal for track welding or production welding with short welds.
 - Turn to **max(0.9s)**: The time the ADF lighten after welding to be longer. The longest time is about 0.9s depending upon welding point temperature and shade set. This setting is ideal for welding at high amperage where there is an after-glow from the weld.

Grinding and Welding SELECTION

- Select grinding mode and Welding mode by switching the button on the ADF, (Position 5) The red light on ADF will flash at Grinding mode (Position 7).

Note: Do not weld in the grinding mode, the ADF will not darken.

BATTERY INDICATOR

- The light on ADF become red (Position 6), Change the battery of ADF. Otherwise, switching time will become slower and shade accuracy will be compromised.

HEADGEAR ADJUSTMENTS

Because the shapes of man's heads vary from person to person, the work positions and the observing angles are different. Operator may adjust the headband in 5 parameters:

- 1- Select eye level by Headband adjusting buttons (1).
- 2- Select view angle by Segmental positioning plate (2).
- 3- Adjust head size perimeter by pushing and turning the Headband tightness adjusting knob (3).
- 4- Select eyes distance from ADF by adjusting Headgear screws to 1 of the 5 slots on the Headgear slider (4). Make sure both sides are equally positioned for proper vision.
- 5- Select the height of the headgear by adjusting the Block washers(5) up or down on the Block washer adjustment(6).

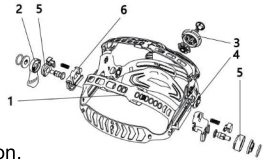

REPLACE INNER VISOR

The Large Inner Visor is a protection lens and must be replaced if broken, damaged or covered with welding spatter to the extent that vision is impaired.

- Flip up the outer cover.
- Push the plugs inside the helmet up, see position 1. The Inner Visor will be released from the helmet; pull the Inner Visor out. See position 2.
- Insert the visor, it is necessary to locate the button into the corresponding hole in the helmet, then push the plugs inside the helmet down and lock the visor
- The user must always make sure the Visor is fitted properly and is locked well and there are no visible gaps.

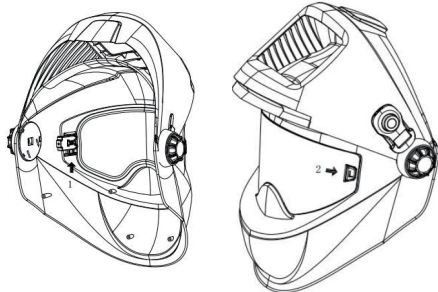

REPLACE OUTER PROTECTION LENS

- The outer protection lens is a protection lens and must be replaced if broken, damaged or covered with welding spatter to the extent that vision is impaired.
- Flip up the outer cover.
- Unlock the ADF by pull the lock structure inside the flip up cover, (position.1). Take the ADF out (Position.2), replace a new outer protection lens. Insert the ADF back to flip up cover, lock the ADF by push the lock structure.
- The user must always make sure the outer protect lens is fitted properly and is locked well

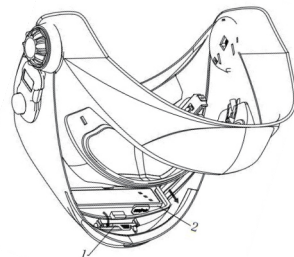

TRUE COLOR

The auto-darkening helmet is a True Color welding helmet. With advanced True Color technology, the users can weld with improved clarity due to new complex coating technology, grinding with precision while in grinding mode and finally see the job performance in the light state in the full spectrum of colors. No need to remove the helmet to see clearly! Results are enhanced the weld quality, increased efficiency and improved safety because the users can see more.

MAINTENANCE

The auto-darkening helmet needs little maintenance. Use a clean, soft piece of cloth moistened with soft soap / pure alcohol / commercial disinfectant to wipe the inside and the outside of the helmet. Dry storage.

Note: Do not immerse the helmet or ADF in water directly.

TROUBLE SHOOTING

Trouble	Remedy
The ADF does not darken when welding.	<ul style="list-style-type: none">-Stop welding or cutting immediately.-Make sure the sensors are facing the arc and no obstructions.-Check the mode that is on WELDING not GRINDING.-Review sensitivity recommendations and adjust sensitivity if possible.-Replace the battery if necessary.
The ADF stays dark after welding or there is no arc present.	<ul style="list-style-type: none">-Adjust the sensitivity to the lower level (level 1).-If the welding place is extremely bright, it is recommended to reduce the surrounding light level.
The ADF switching during the welding.	<ul style="list-style-type: none">-Increase the sensitivity if possible.-Make sure the sensors are facing the arc and no obstructions.-Increase Delay 0.1 – 0.3 second may also reduce switching.
Inconsistent shade number on the corner of ADF.	<ul style="list-style-type: none">-It is a natural feature and will not be dangerous for the eyes.-In order to get a maximum comfort, try to keep an view angle at around 90° .

WARRANTY

The auto-darkening filter are warranted for 2 years from the date of purchase. The duration of use depends on various factors such as use, cleaning storage and maintenance. Frequently inspections and replacement are recommended if it is damaged.

PARTS LIST

Stealth-XG		
No.		Description
1	3026	Outer protection lens 118x97x1mm
2	6044-02	ADF
3	6044-03	Remote control
4	6044-04	ADF (without Remote control)
5	6044-05	Inner protection lens 104.5x64x1mm
6	6044-06	XA-1131(I) ADF SET
7	6044-07	XA-1131(I) ADF
8	6044-08	ADF Frame
9	3021	Inner protection lens 105.8x65.8x1mm
10	6044-10	ADF Lock
11	6044-11	Inner lens SG.PC-SN.1-curve
12	6044-12	Slider lock unit
13	6044-13	Helmet
14	6044-14	Helmet Shell A
15	6044-15	Helmet Shell B
16	6044-16	Headgear
17	6044-17	Sweatband
18	6044-18	Headgear Fasteners
19	6044-19	Dust screen
20	6044-20	Air duct

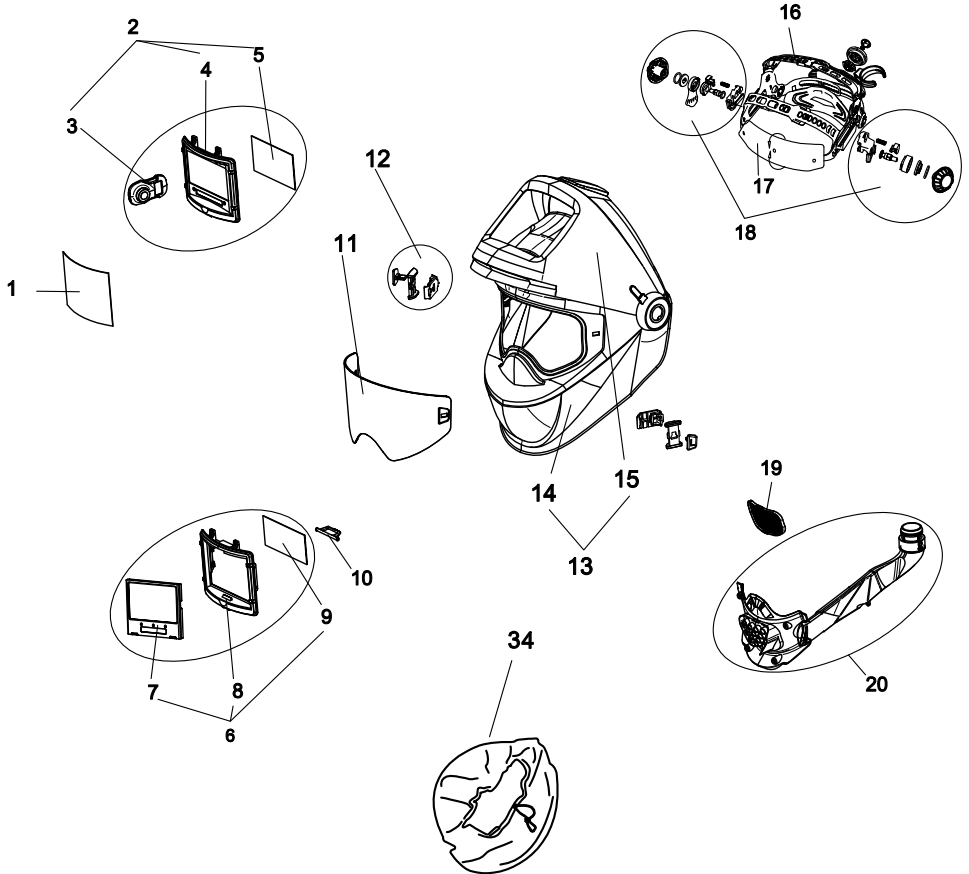

21	4044COV	Filter Cover
22	3044GAU	Spark Arrestor
23	3044PRE	Pre-filter
24	3044P3	Filter
25	3044BLOW	Turbo Unit
26	3044BLT	Waist Belt(PE)
27	3044HARN	Shoulder Harness
28	4044BAG	Carrying Bag
29	6044-29	Breathing Tube flexible 0.6m
30	6044-30	Anti-fire Cloth of Breathing Tube 1.48m
31	3044BAT	Standard Battery 4400mAh
	3044BATHD	Heavy Duty Battery 6800mAh
32	3044CHA	Battery Charger
33	3044TEST	Air Flow Tester
34	6044SEAL	Face Seal

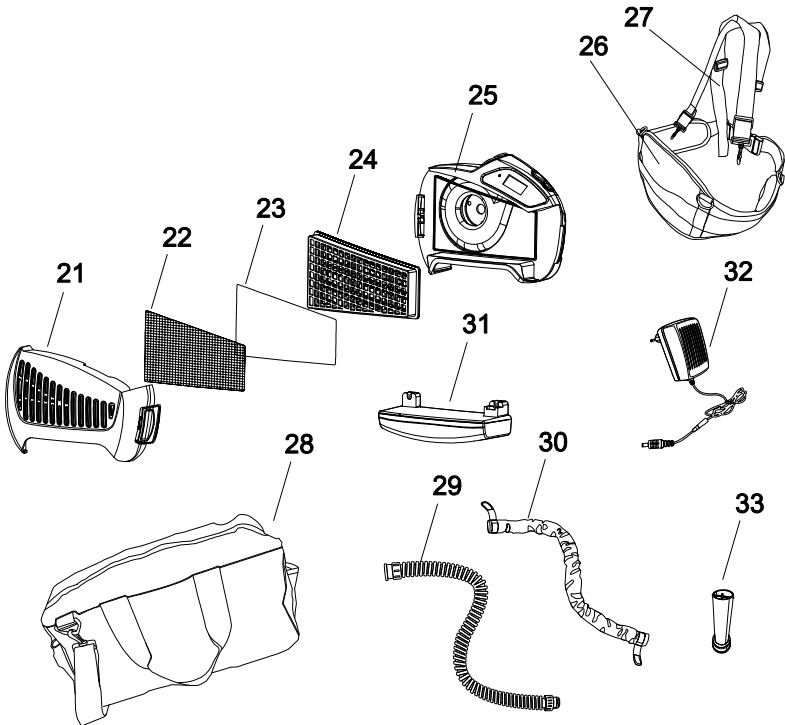

RECOMMENDED SHADE NUMBERS (Table 1)

WELDING PROCESS	CURRENT AMPERES																						
	0,5	1	2,5	5	10	15	20	30	40	50	60	100	125	150	175	200	225	250	275	300	350	400	450
Covered Electrode	Shade 9								Shade 10		Shade 11				Shade 12				Shade 13		14		
MIG Plate Welding	Shade 10										Shade 11			Shade 12			Shade 13				14		
MIG Sheet Metal	Shade 10										Shade 11		Shade 12		Shade 13		Shade 14			15			
TIG	Shade 9		Shade 10		Shade 11			Shade 12			Shade 13		Shade 14										
MAG	Shade 10					Shade 11		Shade 12		Shade 13			Shade 14		Shade 15								
Arc Gouging	Shade 10										11	12	13	14	15								
Plasma Cutting	Shade 11										Shade 12			Shade 13									
Plasma Welding	4	5	6	7	8	9	10	11	12	13			14			15							