

**INSTRUCTION MANUAL
FOR USE
AND MAINTENANCE**

MW8002



INDEX

Par	Description
0	Analytical index of the operating and maintenance manual
INDEX	2
Analytical index of the operating and maintenance manual	2
<i>Purpose of the operating and maintenance manual</i>	4
<i>Storage of the instruction manual</i>	5
<i>Updating of the Instruction Manual</i>	5
<i>Glossary and pictograms</i>	6
<i>Manufacturer's identification data</i>	9
<i>Machine identification and data plates (if they are present)</i>	<i>Error! Bookmark not defined.</i>
<i>Declarations</i>	10
<i>Guarantee activation form (with repairs by authorised centres)</i>	11
MW8002 WELDING FUME EXTRACTOR	<i>Error! Bookmark not defined.</i>
Use and general characteristics.....	12
MW8002 WELDING FUME EXTRACTOR	<i>Error! Bookmark not defined.</i>
Construction features	13
Technical features.....	14
INSTALLATION COMMISSIONING AND START-UP	16
FUNCTIONING	16
Normal use.....	17
Most frequent faults: causes and remedies	17
Risks and emergencies.....	18
MAINTENANCE	19 <i>Error! Bookmark not defined.</i>
MW8002 - Cleaning and change of parts	18
Inspections, controls, repairs, interventions other than ordinary	19
DECOMMISSIONING	20
Dismantling and demolition.....	20
WIRINGS	22
MW8002	<i>Error! Bookmark not defined.</i>

OPERATOR'S NOTES.....	23
Details of maintenance operations	23

INTRODUCTION

Par	Description
1	Purpose of the operating and maintenance manual

This instruction manual is an integral part of the machine and has the purpose of providing all the necessary information for the following purposes:

- Raise the awareness of operators as regards safety matters;
- Safe handling of the machine when packaged and unpackaged;
- Correct installation of the machine;
- Thorough knowledge of the machine's operations and limits;
- Correct use in total safety;
- Correct and safe maintenance;
- Dismantling of the machine in total safety, in compliance with the regulations in force on the health and safety of workers and the environment.



The people in charge of the company's departments in which this machine will be installed must, according to the regulations in force, carefully read the content of this Operating Manual and ensure that operators and maintenance staff operating and working on the machine read the relevant parts.

The time dedicated to this will be fully rewarded by the correct and safe operation of the machine.

This document is based on the assumption that the systems in which the machine is to be installed are in compliance with the health and safety at work regulations in force.

The instructions, drawings and documentation contained in this Manual are of a technical confidential nature and are property of the manufacturer; they may not be reproduced in any way, in part or fully.

If this manual is amended by the manufacturer, the Customer has the responsibility of ensuring that only the updated versions are available in the points of use.

INTRODUCTION

Par	Description
2	Storage of the instruction manual

The instruction manual must be kept safely and must be handed over to new owners in case of sale throughout the lifecycle of the machine.

To help preserve the manual in good condition it must be handled with care and with clean hands, and it must not be placed on dirty surfaces.

It is forbidden to remove, tear out or arbitrarily modify any parts of the manual.

The manual must be stored in an environment away from humidity and heat, in a position near the machines to which it refers.

Upon the User's request the Manufacturer shall supply other copies of the machine's instruction manual.

INTRODUCTION

Par	Description
3	Updating of the Instruction Manual

The manufacturer reserves the right to modify the project and improve the machine without informing customers and without updating the manual already delivered to the User.

If modifications are made to a machine installed at the customer's premises, in agreement with the manufacturer, and which entail the amendment of one or more chapters of the manual, the manufacturer shall send the amended chapters to the holders of the Instruction Manual and its new overall revision.

According to the instructions that will accompany the updated documentation, the User shall replace the old chapters in the copies held with the new ones, as well as the first page and table of contents with the new revision level.

INTRODUCTION

Par	Description
4	Glossary and pictograms

This paragraph lists some terms which are not commonly used or with a meaning different from the common one. The meaning of the abbreviations and pictograms used is described below. The abbreviations and pictograms are used to indicate operator qualifications and state of the machine; they provide, in a quick and univocal manner, the information necessary for the correct and safe use of the machine.

GLOSSARY (Annex I point. 1.1.1 Dir. 2006/42/EC)

HAZARD

A potential source of injury or damage to health;

DANGER ZONE

Any zone within and/or around machinery in which a person is subject to a risk to his health or safety;

EXPOSED PERSON

Any person wholly or partially in a danger zone;

OPERATOR

The person or persons installing, operating, adjusting, maintaining, cleaning, repairing or moving machinery;

RISK

A combination of the probability and the degree of an injury or damage to health that can arise in a hazardous situation;

GUARD

A part of the machinery used specifically to provide protection by means of a physical barrier;

PROTECTIVE DEVICE

A device (other than a guard) which reduces the risk, either alone or in conjunction with a guard;

INTENDED USE

The use of machinery in accordance with the information provided in the instructions for use;

REASONABLY FORESEEABLE MISUSE

The use of the machinery in a way not intended in the instructions for use, but which may result from readily predictable human behaviour.

OTHER DEFINITIONS

MAN-MACHINERY INTERACTION

Any situation in which the operator interacts with machinery in any of the operating phases during the lifecycle of the machinery.

OPERATOR QUALIFICATIONS

Minimum level of skill that an operator must have to carry out the described operation.

NUMBER OF OPERATORS

The suitable number of operators, able to carry out the operation described in an optimal way, as established by a careful manufacturer analysis, whereby a different number of operators might not make it possible to obtain the expected result or might endanger the safety of the personnel involved.

STATE OF THE MACHINE

The state of the machine includes operating modes, for example automatic running mode, jog command, stop, etc., the condition of the safety devices on the machines such as protection devices provided (or not provided), pressed emergency button, type of isolation from energy sources, etc.

RESIDUAL RISK

Risks that persist despite the adoption of the protective measures included in the design of the machine and despite the additional protective devices and measures adopted.

SAFETY DEVICE

Device:

- That carries out a safety function;
- which, when faulty and/or broken, endangers the safety of people.

(e.g. lifting equipment; fixed, mobile, adjustable protective device, etc., electric, electronic, optical, pneumatic, hydraulic device interlocking a protection device, etc.).

PICTOGRAMS

The descriptions that follow this pictogram contain:

Very important information/instructions, in particular as regards safety.

Failure to respect them may lead to:

- danger for the safety of the operators;
- loss of contractual guarantee;
- waiver of the manufacturer's liabilities.

PICTOGRAMS CONCERNING OPERATOR QUALIFICATIONS





Symbol	Description
	Unskilled worker: operator without specific skills that can only carry out simple tasks following the instructions of qualified technicians.
	Driver of lifting and handling means: operator qualified to use machines and material handling and lifting equipment (strictly following the manufacturer's instructions), according to the laws in force in the country of use of the machine.
	Mechanical service man: a qualified technician that can manage the machine in normal conditions, operate in jog mode with the protection devices disabled and work on its mechanical parts to make the necessary adjustments, repairs and maintenance. Usually he is not qualified to work on live electrical systems.
	Electrical service man: a qualified technician that can use the machine in normal conditions, operate in jog mode with the protection devices disabled and work on electrical parts to make the necessary adjustments, repairs and maintenance. He can work on live cabinets and junction boxes.
	Manufacturer's technician: qualified technician provided by the manufacturer to carry out complex operations in particular situations, or in any case as agreed with the user. According to the situation the technician will have mechanical and/or electrical and/or electronic and/or software skills.

Table 0 - 4.1
PICTOGRAMS CONCERNING THE STATE OF THE MACHINE

Pictograms inside a square/rectangle provide INFORMATION.







Symbol	Description
	Machine off: with hydraulic or electric power supply disconnected.
	Machine on: with hydraulic or electric power supply connected and in safe stop condition with open mobile protective devices (specifying which); JOG disabled; fixed protection devices closed.
	Machine on: with hydraulic or electric power supply connected and in safe stop condition with emergency mushroom button pressed or other control with the same function activated, positioned near the intervention area (specifying the mushroom button or the device to be used).
	Machine moving: in automatic mode, with mobile protection devices closed, the relevant interlocking devices activated, and the fixed protection devices closed.
	Machine moving: in JOG mode, with mobile protection devices closed, the relevant interlocking devices activated, and the fixed protection devices closed.
	Machine moving: in JOG mode, with one or more mobile protection devices, that can be disabled, open (specifying which) with the relevant interlocking devices activated and fixed protection devices closed.
	Machine on: in stand-by and waiting for functional consent to start (e.g. presence of product), mobile protection devices closed with safety device closed, and fixed protection devices closed.

Table 0 - 4.2

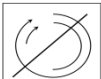
GENERAL INFORMATION

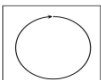
Par	Description
1	Manufacturer's identification data

Importer & UK Distributor

AES Industrial Supplies Ltd

REGISTERED OFFICE – ADMINISTRATIVE OFFICE

Olympic House, Collet, Southmead Park, Didcot, Oxon, OX11 7WB

AFTER SALES/SPARE PARTS SERVICE

Tel. 0044 (0) 1235 510717

Fax. 0044 (0) 1235 818610

E-mail: orders@aes-sales.com

CALL CENTER

Tel. 0800 975 9710

GENERAL INFORMATION

Par	Description
3	Declarations

The machine is manufactured in conformity with relevant EC Directives, applicable when the machine is put on the market.

ANNEX IV Directive 2006/42/EC

The machine does not belong to the category of machines mentioned in Annex IV to directive 2006/42/EC.

EC DECLARATION OF CONFORMITY

(Annex IIA DIR. 2006/42/CE)

The Importer & Sole Distributor

AES Industrial Supplies Ltd		
Company		
Olympic House, Southmead Park	OX11 7WB	Oxfordshire
Address	Postcode	Province
Didcot	United Kingdom	
City	Country	

DECLARES THAT THE MACHINE

Trolley-mounted air cleaner for the extraction of welding fumes	MW8002
Description	Model
- - - - -	- - - - -
Serial number	Year of manufacture
MW8002	
Commercial name	
Extraction and treatment of welding fumes for oil and fat-free light duty processes	
Intended use	

IS IN COMPLIANCE WITH THE FOLLOWING DIRECTIVES

Directive 2006/42/EC of the European Parliament and Council of 17 May 2006 on machinery and amending directive 95/16/EC.

Directive 2004/10/8/EC of the European Parliament and Council of 15 December 2004 on the approximation of the laws of the member States relating to electromagnetic compatibility.

Directive 2006/95/EC of the European Parliament and Council of 12 December 2006 on the approximation of the laws of Member States relating to electrical equipment designed for use within certain voltage limits.

Reference to harmonised standards:

EN 349:1993+A1:2008, EN 614-1:2006+A1:2009, EN 614-2:2000+A1:2008, EN 626-1:1994+A1:2008, EN 626-2:1996+A1:2008, EN 842:1996+A1:2008, EN 894-1:1997+A1:2008, EN 894-2:1997+A1:2008, EN 894-3:2000+A1:2008, EN 953:1997+A1:2009, EN 1005-2:2003+A1:2008,
EN 1037:1995+A1:2008, EN 1037:1995+A1:2008, EN 1093-1:2008, EN 1093-4:1996+A1:2008, EN 13478:2001+A1:2008, EN ISO 13849-1:2008,
EN ISO 13849-2:2008, EN ISO 13850:2008, EN ISO 13857:2008, EN ISO 14121-1:2007, EN ISO 14159:2008

GENERAL INFORMATION

Par	Description
4	Guarantee activation form (with repairs by authorised centres)

BUYER'S DETAILS:

COMPANY NAME ▼
_____BUSINESS/PROFESSION/DEPARTMENT ▼
_____USER DATA (Surname and Name) ▼
_____PLACE OF INSTALLATION ADDRESS ▼

POSTCODE ▼

CITY ▼

Telephone ▼

Fax ▼
_____e-mail ▼
_____Data di acquisto ▼
_____Model ▼

Serial number ▼

accessory/ies ▼

Section to be filled in and returned in a sealed envelope to:

AES Industrial Supplies Ltd
Olympic House, Collett,
Didcot, OX11 7WB

Please enclose also a copy of the purchase document (delivery note, invoice, receipt) showing the date of purchase.

In accordance with article 10 of Law 675/96 data provided in this form shall be recorded on protected electronic supports and shall be treated using computerised systems; data must be provided in order to enter into and execute the contractual relationship established by the Guarantee. Data may be used by service and by specialised companies operating in Italy and abroad on behalf of service S.r.l., for customer communications.

Pursuant to article 13 of Law 675/96, you may, at any time and free of charge, check the data held and obtain the rectification or erasure of the data; you also have the right to object in full or in part to the use of the data for the purposes described above, by writing to AES Industrial Supplies Ltd, for the attention of the Data Controller.

Check this box if you do not consent to the use of the data provided for purposes other than the management of the Guarantee

Customer's Signature _____



12 MONTH GUARANTEE ACTIVATION REQUEST FORM



aeservice
Equipments for air pollution

This GUARANTEE gives the right to telephone assistance and to interventions by qualified service personnel to restore the equipment following problems caused by manufacturing faults; this guarantee is valid for 12 months from the date of purchase.

The guarantee does not cover any damage to the outer enclosures or faults caused by natural events (lightening, flooding, etc), intent, improper use or use of incompatible consumables.

The Guarantee does not cover consumable parts such as filters, flexible hose, lamps, etc.
Any assistance carried out by unauthorised personnel shall invalidate the guarantee,

To benefit from the Guarantee please fill in the upper section of this card and send it in a sealed envelope, within 10 days from the date of purchase of the equipment, to the following address: AES Industrial Supplies Ltd, Olympic House, Southmead Park, Didcot, OX11 7WB

Please attach a copy of the purchase document, or send all documents via fax to +39 049 825 2310, or to the website www.service.it.
Keep this section of the card together with the original purchase document to certify your right to the Guarantee.

For telephone support or technical assistance please call: +39 049 641 200

MW8002 Welding Fume Extractor

Par	Description
1	Use and general characteristics



Use

The MW8002 welding fume extractor series are particularly suitable to be used in businesses where the welding operation is occasional and still in the presence of low concentrations of fumes, i.e. for those who, for reasons dictated by their activity, must perform welding at an address of third where the need to transport the purifier is a primary requirement. With the latest regulations for this type of use exhaust fans located at the auto repair shop to clean up the welding fumes.

MW8002 Welding Fume Extractor

Par	Description
2	Construction features

The portable welding fume extractor MW8002 is made by:

- **external metal structure**, painted steel of suitable thickness, in such a way as to make the purifier resistant to accidental impacts due to the use and to the movement. The property is also equipped with a convenient handle and wheels to facilitate transport;
- **filter section** comprising a prefilter in metal wool with spark proof function, by one or two paper filters pretreated depending on the version and an active carbon filter;
- **electric motor** with single-phase;
- **hose and suction nozzle** with magnet and tube;
- **electric control panel** and plug CEE norm.

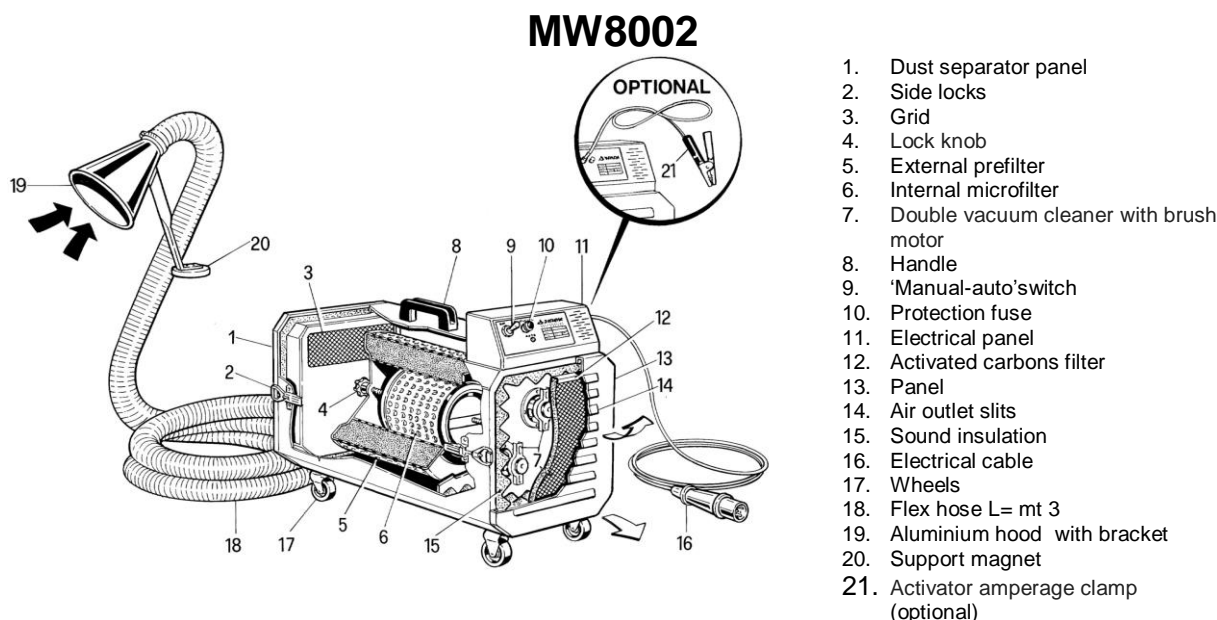

MW8002 Welding Fume Extractor

Par	Description
3	Construction features

The portable cleaner adopts mechanical filtration system to purify the air. The air is sucked in through the nozzle, positioned near the pollutant source and connected to the purifier by means of flexible tubing, through the filtration section in which occurs the separation of the particulates (dust present in welding). After this first stage of separation, the air passes through the fan first and then pass through a panel with activated carbon for deodorization.

- **MW8002**, with filter section comprising a filter paper in high efficiency $\varnothing = 280$ mm L = 390 mm, from an absolute filter $\varnothing = 180$ mm L = 375 mm and an active carbon filter 225x265 mm. The suction is obtained by two motors in parallel, individually operated, only one or both simultaneously. is also used as a scavenger to be applied to the welding torches low amperage provided apparatus for the aspiration of fumes.

Carchteristics	MW8002
ON OFF switch	YES
Complete control panel	YES
Automatic start device	Optional
Activated carbons filter 210 x 210 mm	-
Activated carbons filter 225 x 265 mm	YES
Paper filter $\varnothing=195$ L=285 mm	-
Paper filter $\varnothing=280$ L=390 mm	YES
Absolute filter $\varnothing=180$ L=375 mm	YES
Flexible hose $\varnothing=50$ mm L=3 m	YES
Conical extraction nozzle	YES
Magnet for the hood	YES
Extracting torch	-

MW8002 WELDING FUME EXTRACTOR

Par	Description
1	Technical features

Unit	MW8002	
Suction arm	N°	1
Supply voltage	V	230
Frequency	Hz	50
Power	kW	2.2
Absorbed current	A	9.7
Max flow rate - arm	m ³ /h	500
Pressure drop - machine	Pa	4400
Protection class IP		55
Insulating class ISO		F
Flow rate - machine	m ³ /h	220
Filtration efficiency ref. EN 779	%	G2 25%
	%	F5 85%
	%	F6 90%
Active carbon (if present)	Kg	2
Sound level	dB(A)	77
Weight - machine	Kg	37

INSTALLATION COMMISSIONING AND START-UP

Installation

For installation you must provide the electrical connection that can be made for reasons of practicality with plug and socket 2 x 16 + T to be installed by the user.

To make the connection of the vacuum cleaner by grafting the filler hose for the conveyance of the fumes and which in turn is connected to the element sensor.

It is advisable to protect the unit from moisture.

WARNINGS

Before installation, check the mains voltage.

Commissioning

It is recommended to include the use of the device by the following environmental conditions:

- The ambient operating temperature of the machine is between -10 ° C and 60 ° C
- The humidity of the indoor environment in which the work is carried out must be between 0% and 90%

Recommendations / Instructions:

- The elimination/removal of any waste materials should be carried out according to the regulations
- For cleaning or replacing the filters using the mask and protective gloves.

Description of manual controls

The activation of the purifier MW8002 is obtained manually by moving the switch from position to position or manual gear and automatically moving the switch to automatic operation. So it is prepared for operation in automatic by inserting into the jack of the activator applied to the ground lead on the stroke of the welding arc will close the circuit controlling the activation of the purifier. In the case that both purifiers are not activated to check the efficiency of the respective fuses, checking any abnormalities of electrical character.

Before startup, check that the mains voltage is in accordance with what is set at installation time.

ATTENTION:

Both containers and metal structures connected to it should be thoroughly grounded as required by safety regulations.

For this reason, it must be available near the equipment MW8002 an effective line of grounding.

The **test** is carried out at the manufacturer's premises, prior to shipment.

Starting

After carrying out the above checks, turn on the mechanical purifier with the switch on the panel and connect the collector element, connect the activator attacking him with a clamp to the ground wire from the generator and engage into the jack located on the front door of the air cleaner tools.

FUNCTIONING

Par	Description
1	Normal use

The welding fume extractor MW8002 has been designed and built for low to medium use. The cleaner should be used exclusively for mechanical exhaust of smoke, fine dust, gas, gaseous pollutants in low concentrations through the torch hood or hose, the end of which is connected with the appropriate filler plug on the door instead of a treatment plant mechanic. Remember that: the law allows recycling in environment only if it is occasional welding operations. The manufacturer is not liable for any use other than as described.

Not to do

- Do not remove the air cleaner filter panels with mechanical function
- In general, do not dismantle or remove any part of the mechanical treatment plant when it is in use or connected to
- Do not insert the power cord in the closures of the panels
- Do not tamper with the components of the electrical panel
- Do not run the vacuum cleaner along with the suction nozzle closed
- Do not pick up liquids
- Do not place hot objects (eg cigarette butts)

IMPORTANT NOTE

THE EQUIPMENT SHOULD NOT BE USED IN EXPLOSIVE ATMOSPHERE

FUNCTIONING

Par	Description
2	Most frequent faults: causes and remedies

Given that most of the malfunctions occur for improper use of the system, are indicated in the table below some possible faults that may occur, and the measures to be taken to remedy them.

FAULT TYPE	CAUSES	ACTION
The cleaner suddenly stops	Power outage	Restore the power supply
	The fuse is burned	Change
	Motor is burned	Repair or change
The yield of the mechanical cleaner is decreased	Filters are dirty	Repair or change
Fumes are escaping	Wrong installation of the filters	Check the closures of the panels and seals

Bad smell	Activated carbons filter full	Change
-----------	-------------------------------	--------

FUNCTIONING

Par	Description
3	Risks and emergencies

Risks

Description hazards and specific protections

The manufacturer has, however, taken steps to reduce the dangers that can arise due to incorrect use of the machine by installing on the machine itself of the protection devices.

Description hazards cannot be eliminated by the security measures adopted

The dangers cannot be eliminated by the security measures taken by the manufacturer are caused by incorrect use of the machine or by a failure on the part of the user of the safety instructions in this manual (refer to the above concerning the things do not do).

As already mentioned above we recommend the use of gloves and mask during cleaning and filter change, in order to avoid the possible consequences to the operator.

Emergency situations

In case of fire:

- Use powder comply with standards
- Pay attention to the combustion gases (polyester filters and plastic electrical plant)

The materials and substances used in the construction of the equipment does not pose a risk of explosion.

IMPORTANT NOTE

THE EQUIPMENT SHOULD NOT BE USED IN EXPLOSIVE ATMOSPHERE

MAINTENANCE

Par	Description
2	MW8002 - Cleaning and change of parts

For model MW8002 open the dust separating panel (1) from the entrance of fumes acting on the enclosure (2), then after removing the grill (3) must be emptied of the parts that were deposited on the inside.

Then unscrew the locking knob (4) Cartridges (pre-filter (5) external microfilter (6) inside) and then take them off outside taking care not to drop them. Pull out the fine filter and wash with a jet of air from inside to outside the pre-filter and same goes also to the microfilter.

Then replace the cartridges one inside the other and reposition them in their seat blocking in the bottom panel (4).

From the side air outlet remove the panel (7) acting on the side locks but not before having removed with a tool safety screw.

Remove from the place the carbon filter (8) and replace it with a new one, making sure to put it back properly when you replace the blanking plate (7) in its place.

Example of the progression of the reduction process.

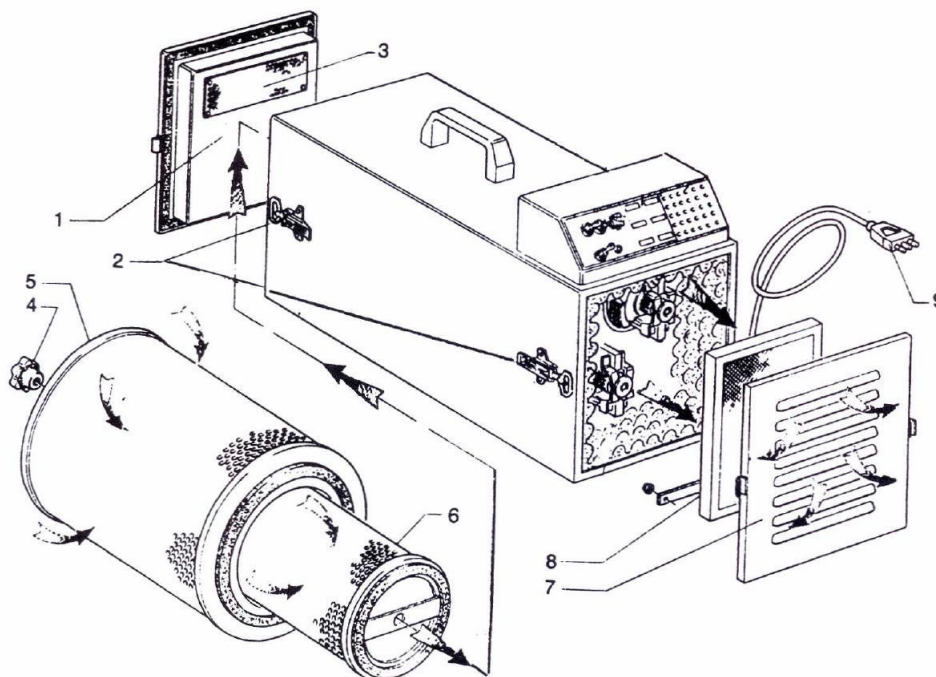

ATTENTION:

All these operations have to be done absolutely by the socket (9) disconnected from electricity.

MAINTENANCE

Par	Description
3	Inspections, inspections, repairs, interventions other than ordinary

The engine of the model MW8002 is equipped with brushes, with detachment that reached a certain degree of wear they touch blocking the operation of sewage treatment plant. To replace them, follow the diagram below.

ESTRARRE IL VECCHIO GRUPPO INSERTO
PULL OUT OLD INSERT ASSEMBLED



INSERIRE IL NUOVO GRUPPO INSERTO
PUT IN NEW INSERT ASSEMBLED



Please note that regular maintenance of the system in general durability.

Periodic maintenance of the filters

The maintenance intervals recommended periodic maintenance are listed below.

GROUP TO CHECK	FREQUENCY OF CONTROL	OPERATIONS TO DO
Sportello contenitore di decantazione	When checking the filters	Drain off and blow with compressed air
Prefilter cartridge	When the extraction is low	Blow with compressed air
Microfilter cartridge	About every 300-500 hour	Change
Carbons	When the expelled air has bad smell	Change

The filters should be replaced after 2 or 3 cleanings.

The filters, when replacing, be disposed of according to regulations.

For the replacement of the filters follow as described previously.

Non-ordinary interventions

Involves repair and replacement of one or more system components that normally are necessary after years of successful operation and does not alter the characteristics of the machine.

In case of substantial changes, the manufacturer cannot be held responsible for any dangers that might arise.

DECOMMISSIONING

Par	Description
1	Dismantling and demolition

DISMANTLING – PUTTING OUT OF SERVICE

Should you decide not to use the equipment, or replace it with another, you must proceed with dismantling and putting out of service.

This operation should always be made in compliance with current regulations.

DEMOLITION, DECONTAMINATION, SEPARATE DIVISION OF THE MATERIALS AND DISMANTLING

If the equipment, or part of it, has been put out of service, its parts must be made innocuous do not cause any danger.

The materials making up the machine, to subject to a separate division, are:

- Steel
- Rubber
- Conductors of electrical system
- Plastic
- Fabric of the filters
- Aluminium
- Activated carbon
- Slag materials
-

All these operations and final disposal should always be made in compliance with applicable provisions of law.

WIRINGS

Par	Description
2	MW8002

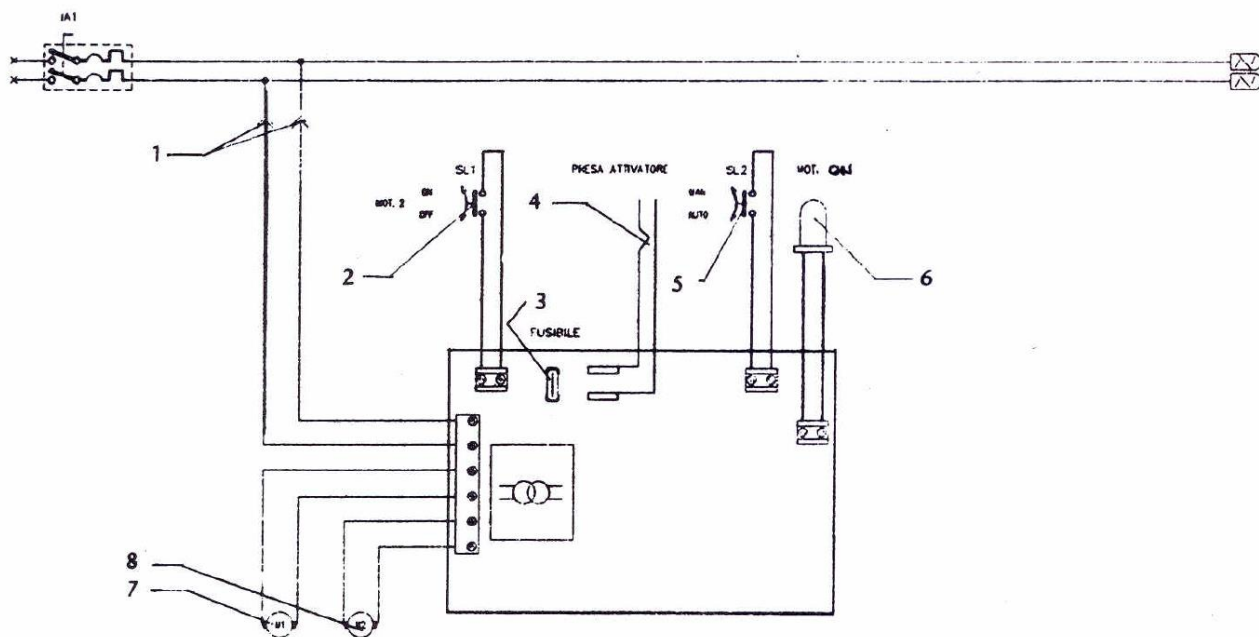

Ref	Description
1	Power connection plug and socket 220V 2 x 16-T
2	Start-stop switch motor 2
3	Fuse 10 Amp
4	Jack socket for activator
5	Manual-automatic gear selector
6	Light signaling motor running
7	Motor 1 220 V 800 Watt
8	Motor 2 220 V 800 Watt

OPERATOR'S NOTES

Par	Description
1	Details of maintenance operations

The following table must be filled in by a qualified technician authorised by AES Industrial Supplies Ltd

It is important keeping up to date these notes in order to have a history of previous problems and maintenances; in this way future malfunctioning could be solved in a shorter time with cost savings.

DATE	COMPANY NAME	CONTACT PERSON	OPERATION CARRIED OUT
			<i><u>First start-up</u></i>

MW8002

**Importer & Distributor of
Masterweld Products;**
AES Industrial Supplies Ltd
Olympic House, Collet,
Southmead Industrial Park
Tel. +44 (0) 1235 510717
Fax. +44 (0) 1235 818610
E-mail: orders@aes-sales.com
www.masterweld.co.uk